



Phason

☰ ← Status 14:57:29

Zone 1 72.3 °F	STG2 24-in 	Outdoor 72.8 °F
Set Point 71.5 °F		Status 40 %

← STG1 36-in  Inlets →

 **PLUS**
TOUCH SERIES

34340003
Copyright Phason Inc.
All rights reserved.

Table of contents

Chapter 1: Introducing the Plus Touch Series	5
Getting to know the Plus Touch	5
Capabilities	6
a	7
Becoming familiar with Plus Touch	7
Unlocking the screen	8
Chapter 2: Installing the Plus Touch	9
What you need to know before installing the Plus Touch	9
Understanding power surges and surge suppression	9
Reducing electrical noise using filters	10
Electrical ratings	11
Using power contactors to increase the capacity of relays	11
Bottom layout	12
Cover layout	13
Mounting the Plus Touch	14
Connecting equipment to the Plus Touch	14
Connecting actuators	14
Connecting curtain machines	16
Connecting cooling, heating, and duty cycle equipment to relays	17
Connecting variable heating or cooling equipment	18
Using three-phase power	19
Connecting an alarm system	20
Connecting Phason 3K temperature sensors	21
Connecting DOL sensors	22
Connecting the power source	23
Finishing the installation	24
Chapter 3: Configuring your Plus Touch	25
What you need to know before configuring	25
Configuring the main control functions	26
Setting the clock	26
Selecting the units of measure	26
Configuring hysteresis	27
Configuring relay stagger	28
Configuring alarm silencing	28
Configuring the zone control mode	29
Using THI for zone control	30
Configuring sensor inputs	30
Configuring equipment	32
Configuring variable stages	32
Configuring relays	33
Configuring relays for inlet actuators or curtains	34
Calibrating inlet actuators	35
Configuring evaporative cooling	36
Chapter 4: Programming the Plus Touch	37
Before you program the Plus Touch	37
Programming zone settings	38
Programming the master set point	38

Programming growth curves	39
Programming minimum ventilation curves	41
Programming modifiers	43
Programming alarms	45
Programming equipment settings	47
Programming merged ventilation	48
Programming variable cooling stages.....	49
Programming variable heating stages.....	51
Programming inlet actuators	53
Programming curtain control relays	54
Programming relay stages	56
Programming duty cycles.....	56
Programming evaporative cooling	58
Programming timed events	67
Using settings groups.....	68
Chapter 5: Monitoring and maintaining your Plus Touch.....	70
Monitoring the Status screen.....	70
Widgets	71
Acknowledging alarms	72
Testing sensors and equipment.....	72
Using manual override.....	72
Testing a zone's sensors and equipment	73
Using screen lock security	74
Servicing and maintaining your Plus Touch.....	75
Restoring the factory defaults.....	75
Saving and restoring settings.....	75
Displaying the firmware version.....	76
Updating the firmware	77
Replacement kits and optional accessories.....	78
Appendixes	80
Appendix A: Troubleshooting.....	80
Possible causes and solutions	80
Determining correct actuator feedback wiring	83
Appendix B: Factory defaults	84
Appendix C: Installation worksheet	85
Appendix D: Configuration worksheets.....	87
Main control function worksheet	87
Variable stage configuration worksheet	88
Relay configuration worksheet	89
Appendix E: Settings worksheets.....	90
Growth curve worksheet.....	90
Variable stage settings worksheet.....	91
Inlet actuators settings worksheet	91
Curtain worksheet.....	93
Heating, cooling, and duty cycle relay worksheet	93
Timed events worksheet.....	94
Alarm settings worksheet	95
Appendix F: Motor curves	96
Service and technical support.....	97

Chapter 1: Introducing the Plus Touch Series

Getting to know the Plus Touch

Plus Touch brings a wealth of features that make it a powerful, versatile, and easy to use control.

Plus Touch has two variable AC stages and six relays to automatically control temperatures by operating ventilation, heating, and cooling equipment according to your programmed settings.

Plus Touch is more than a temperature-based control; it can use other environmental conditions to influence how it controls equipment. For example, if the humidity is too high in the zone, Plus Touch can switch heaters on or increase ventilation to reduce it.

In addition to traditional staged control, Plus Touch offers **VentGrid™** merged mode. Merged ventilation mode has up to four steps, with the benefit that merged mode can provide smoother transitions between steps than staged mode can between stages.

The growth and ventilation curves are powerful features that allow you to automatically change the temperature set point and minimum ventilation rate over time to adjust to requirements as your animals grow.

Easy to program, manage, and monitor

The touchscreen display allows you to easily configure, program, and check the status of zones and equipment. From the status screen, you can easily access configuration, settings, and more. Every powerful feature is never more than a few taps away. This makes the Plus Touch one of the easiest-to-use and user-friendly controls.

Security and peace of mind

Plus Touch has a screen lock security system. While screen lock is enabled, users must enter the PIN before they can access any of the control's functions, except the main status screen.

Plus Touch is compatible with most alarm systems. You can connect the control to an alarm siren or other external alarm system. Customizable alarm settings allow you to choose which alarm conditions you want to be notified about.

Capabilities

Programming options

Independent control zones	2
Automatic temperature control	✓ -13 to 125°F -25 to 51°C
THI control	✓
Staged ventilation mode	✓
VentGrid™ merged ventilation	✓ 4 steps
Manual override mode	✓
Growth curves	2
Minimum ventilation curves	2
Secondary modifiers	✓
Settings groups	✓
Relay stagger for distributing startup load	✓
Hysteresis	✓

Other

5-inch touchscreen	✓
Scrolling status screen	✓
Updatable firmware	✓ Via USB
Transferable settings	✓ Via USB
Diagnostics	✓
Hourly and daily logs	✓
NEMA 4X enclosure	✓ Corrosion-resistant, water-resistant, and fire-retardant
CSA approval	✓
CE certification	✓
2-year warranty	✓

Stages and relays

Variable AC stages	2
0 to 10 V DC signal outputs	4 With optional VDC-4 module
General-purpose relays	6
Alarm relay	✓

Variable and relay configuration options

Variable cool and heat	✓
Relay cool and heat	✓
Duty cycle	✓
Actuator / inlet	✓ Up to 2
Curtain machine / winch	✓ Up to 6
Evaporative cooling	✓
Timed events	✓
VFD control	✓

Sensor inputs

Phason 3K Series temperature	5 30-ft. sensor included
Outdoor temperature	✓
Phason humidity sensor	✓
DOL 114 temp. and humidity	✓
DOL 119 carbon dioxide (CO2)	✓
DOL 53 ammonia (NH3)	✓

a

Becoming familiar with Plus Touch



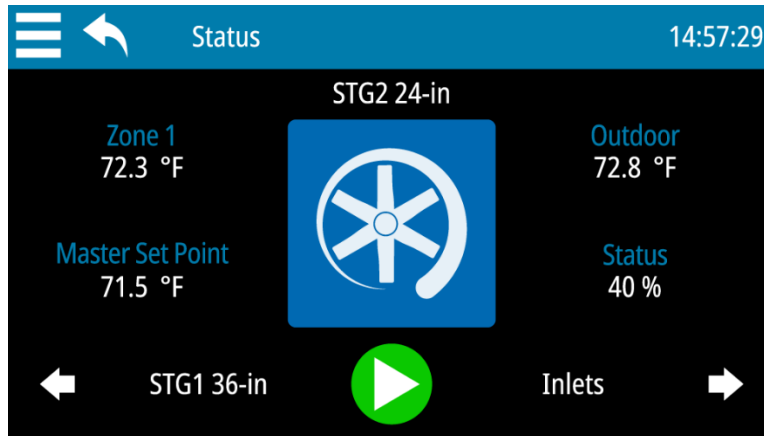







The Status screen is the “home” screen. The status screen is where you can find all basic information at a quick glance.



From the status screen, you can easily access configuration, settings, and more by pressing the menu in the top left corner. Every powerful feature is never more than a few taps away. This makes the Plus Touch one of the easiest-to-use and user-friendly controls. For more information about the status screen, read Menu and main screens on page 70.

Icons

Here is a list of common icons you will use to interact with your Plus Touch.

- | | |
|--|---|
|  HOME
Go to the status screen. |  SAVE
Save changes. |
|  MENU
Go to Manual Override, Settings, Configuration, Administration, Screen Lock, and About Menus. |  CANCEL
Discard changes and return to the previous screen. |
|  BACK
Go to the previous screen. |  PLAY
Play / resume the status screen. |
|  UP/DOWN
Increase / decrease values. |  PAUSE
Pause the status screen. |
|  LEFT / RIGHT
Move / scroll through zones, equipment, or sensors. |  ALARM
View the active alarm condition. |
|  UNLOCK
Enter the PIN to unlock the screen. | |

Menu layout

☰ → MANUAL OVERRIDE	SETTINGS	CONFIGURATION	ADMINISTRATION	SCREEN LOCK	ABOUT
	Staged ventilation Relay stages Ventilation curve Actuator settings Variable stages Duty cycles Curtain settings	Equipment Relays Inlets VACs VDCs Soaking	Screen lock Restart control Restore defaults Show diagnostics Saved to USB Load from USB Update firmware Show version		
	Merged ventilation Master set point Growth curve Heating Relay stages Duty cycles Variable heat	Sensors Hysteresis Units Relay stagger Date and time Zone control mode Alarm silencing			
	Alarms Modifiers Settings groups Timed events Soaking				



If you leave the control in a menu or screen other than Status, the control returns to the Status screen after five minutes without any key presses.

Unlocking the screen

Screen lock security is a feature you can use to control who makes changes to the control's settings. By default, screen lock is not enabled.

While screen lock is enabled, users must enter the PIN before they can access the any of the control's functions except the main status screen. For more information, read **Using screen lock security** on page 74.

To unlock the screen

1. Press the **Lock** and then enter the four-digit PIN.
2. Press **Unlock Screen**.

Chapter 2: Installing the Plus Touch

What you need to know before installing the Plus Touch

1. Read **Understanding power surges and surge suppression** below.



- ◇ If you do not install external surge suppression devices, you risk damage to the electronics inside the Plus Touch, which may cause the Plus Touch to fail.
- ◇ Because it is not possible to **completely** protect this product internally from the effects of power surges and other transients, we **highly recommend** that you install external surge suppression devices. For specific recommendations, see your electrical contractor.
- ◇ If you do not take these precautions, you acknowledge your willingness to accept the risk of loss or injury.

2. List all the equipment you want to control using this Plus Touch on the **Installation worksheet** on page 85. Install the equipment and make your electrical connections according to the sheet.
3. Use the **Configuration worksheets** starting on page 87. List which relays and variable stages you want to use for each piece of equipment, and how you want the equipment configured.

You can connect more than one piece of equipment to a single relay or stage **as long as the total current draw does not exceed** the relay or stage's limit. For more information, see the electrical ratings on page 11.

Understanding power surges and surge suppression

Power surges can be caused by external influences (influences outside the barn; for example, lightning or utility distribution problems) or they can be caused internally (inside the barn; for example, starting and stopping inductive loads such as motors).

One of the most common causes of power surges is lightning. When lightning strikes the ground, it produces an enormously powerful electromagnetic field. This field affects nearby power lines, which transmit a surge to any device connected to it, such as lights, computers, or environmental controls like the Plus Touch. Lightning does not have to actually strike a power line to transmit a surge.

Surge suppression devices offer some protection from power surges. Because it is not possible to internally protect this product completely from the effects of power surges and other transients, Phason **highly recommend** that you install external surge suppression devices. For specific recommendations, see your electrical contractor. If you do not take these precautions, you acknowledge your willingness to accept the risk of loss or injury.

Reducing electrical noise using filters

Electrical noise is caused by high voltage transients created when inductive loads, such as power contactors, are switched on or off. The strength of the transients can be over 1000 volts and can vary with the type of equipment and wiring, as well as several other factors.

Visible symptoms of electrical noise include erratic control operation, cycling inlets, communication problems, and more. However, the **effects of electrical noise are not always visible**. Over time, electrical noise can cause electronic circuits, relay contacts, and power contactors to deteriorate.

Installing filters helps extend the life of equipment

Filters help prevent electrical noise problems by absorbing the transient energy. Even if you do not have **visible symptoms** of electrical noise, filters help keep controls operating reliably and can extend the life of the controls and equipment connected to them.

Phason's snubber filters (**model 127-0**) are for use with solenoids, timer relays, DC motors, furnaces, and other equipment connected to the control's relays. You can also use the filters with loads connected to power contactors..

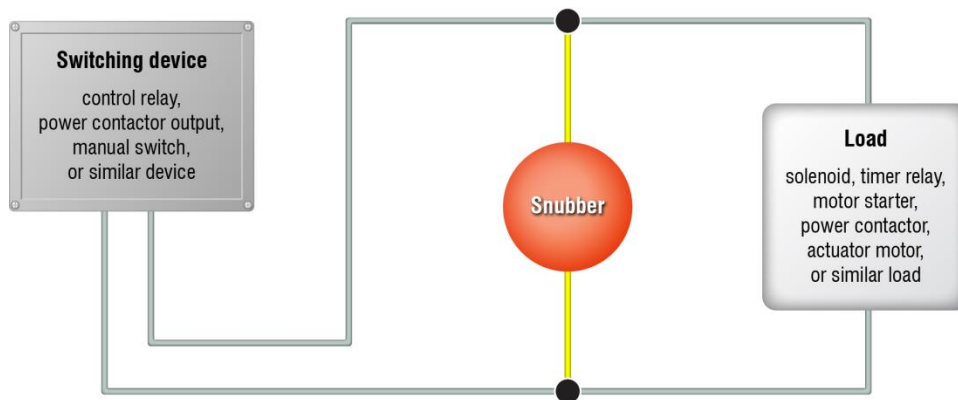

- ◇ Do not use Snubber filters with variable stages.
- ◇ Some power contactors include snubber filters. For more information, read **Using power contactors to increase the capacity of relays** on page 11.
- ◇ For more information about snubber filters or other Phason accessories, see your dealer or visit www.phason.ca.

Electrical ratings

Input power	120/230 VAC, 50/60 Hz
Variable stages ① (2: VARI-1, VARI-2)	10 A at 120/230 VAC, general-purpose (resistive) 7 FLA at 120/230 VAC, PSC motor 1/2 HP at 120 VAC, 1 HP at 230 VAC, PSC motor
Fuses (2: F1 and F2)	15 A, 250 VAC ABC-type ceramic
Relay stages ① (6: STG-1 to STG-6)	10 A at 120/230 VAC, general-purpose (resistive) 1/3 HP at 120 VAC, 1/2 HP at 230 VAC 360 W tungsten at 120 VAC
Alarm relay	0.4 A at 125 VAC; 2 A at 30 VDC, resistive load 0.2 A at 125 VAC; 1 A at 30 VDC, inductive load

① You can connect more than one piece of equipment to a variable stage or relay as long as they are the same type (for example, two fans) and the total current draw does not exceed the stage's limit.



The FLA (full load ampere) rating accounts for the increase in motor current draw when the motor operates at less than full speed. Make sure the motor/equipment connected to the variable stage does not draw more than 7 FLA.

Using power contactors to increase the capacity of relays

Phason's Manual Override Box (**model MOB-4**) has four 240-volt power contactors that allow you to increase the load handling capability of control relays. Manual Override Box is ideal for secondary ventilation fans and electric heaters.

MOB-4 electrical ratings

- ◆ Coil: 10.2 mA at 240 VAC
- ◆ Contact: 25 A at 240 VAC; resistive
2 HP at 240 VAC, 1 HP at 120 VAC; motor, power factor 0.4
1300 W at 120 VAC; tungsten

For more information, read **Replacement kits and optional accessories** on page 78 .

Bottom layout

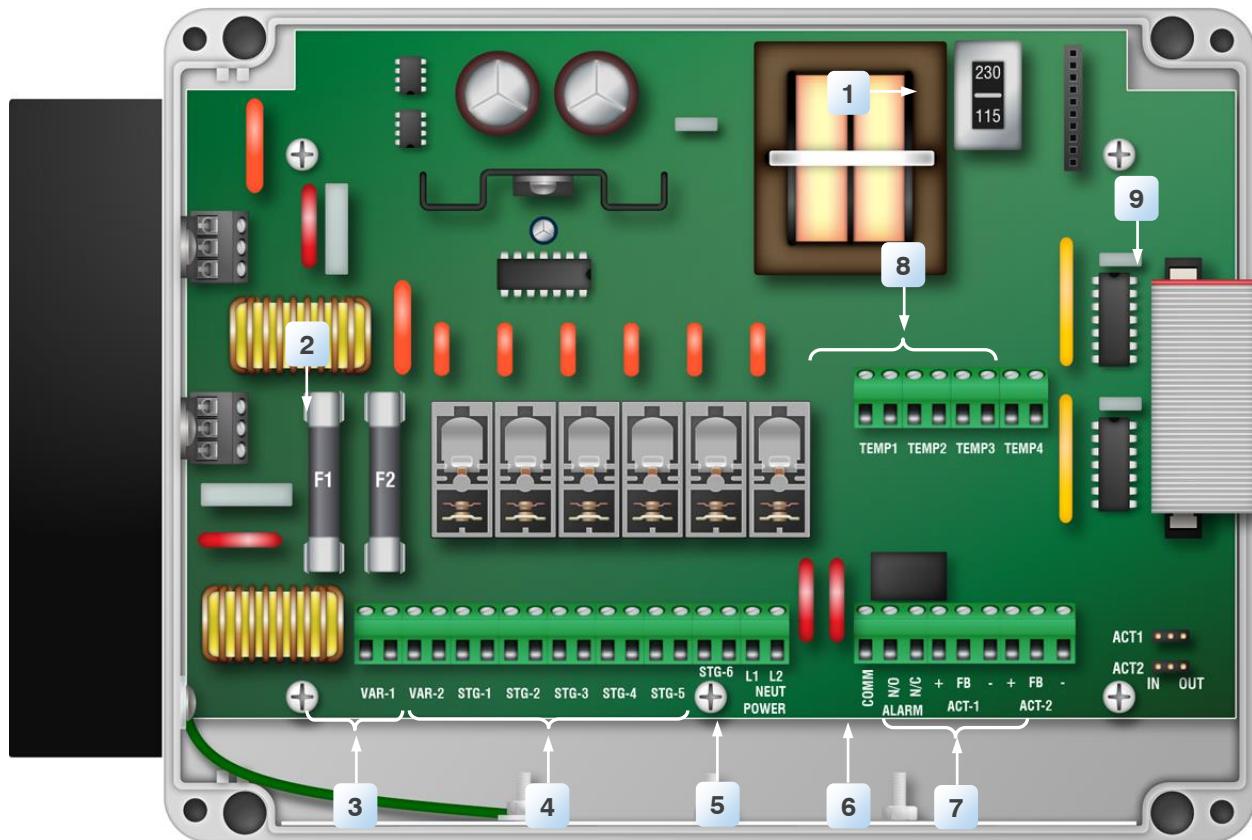

- 1 **Voltage selection switch** – set this switch to the correct voltage before installing the Plus Touch.
- 2 **Variable stage fuses (F1, F2)** – 15 A, 250 VAC ABC-type ceramic; F1 VAR 1, F2 for VAR 2.
- 3 **Variable stage terminals (VAR1, VAR2)** – connect variable speed fans to these terminals.
- 4 **Relay terminals (RLY1 to RLY6)** – connect single stage (on/off) equipment to these terminals. You can configure these relays as heat, cool, duty cycle, inlet, or to follow another variable or relay.
- 5 **Incoming power terminal** – connect the incoming power (120/230 VAC, 50/60 Hz) to this terminal.
- 6 **Alarm relay terminal** – connect an external alarm system or alarm siren to this terminal.
- 7 **Actuator feedback terminals (ACT1 and ACT2)** – connect the feedback from the actuators to these is terminals.
- 8 **Phason 3K temperature sensor terminals (TEMP1 to TEMP4)** – connect the sensors to these terminals.
- 9 **Display cable** – make sure the ribbon cable from the display is properly connected to the socket.

Cover layout

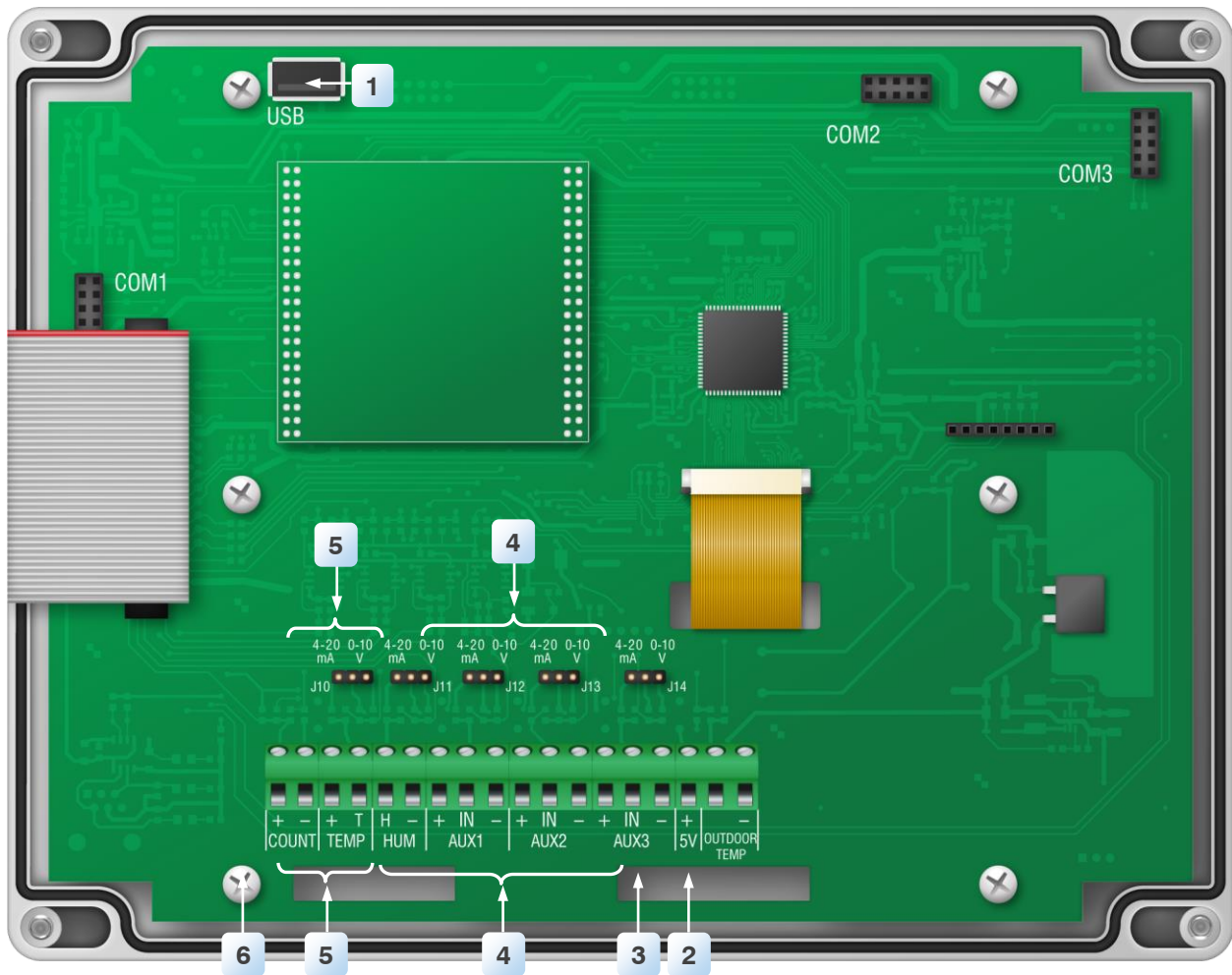

- 1 **USB** – connect a USB drive when saving or loading settings, or updating firmware.
- 2 **OUTDOOR** – connect a Phason 3K Temperature Sensor for measuring outdoor temperature.
- 3 **+5V** – can provide +5 VDC
- 4 **DOL (AUX1 to AUX3)** – connect DOL 119 Carbon Dioxide or DOL 53 Ammonia Sensors.
Place the jumpers on the correct pins.
- 5 **DOL 114 (TEMP / HUM)** – connect a DOL 114 Temperature and Humidity Sensor.
Place the jumpers on the correct pins.
- 6 **Pulse counter (COUNT)** – not available, used for future development

Mounting the Plus Touch

1. Select a location for the Plus Touch. Make sure you have enough cable and wire to reach all the equipment (fans, heaters, misters, curtains, etc.) that you want to control.
2. Remove the screws from the front cover and then gently lift it off.
3. Mount the enclosure to a wall using the four screws provided with the control. Insert the screws into the large holes in each corner of the box and tighten.

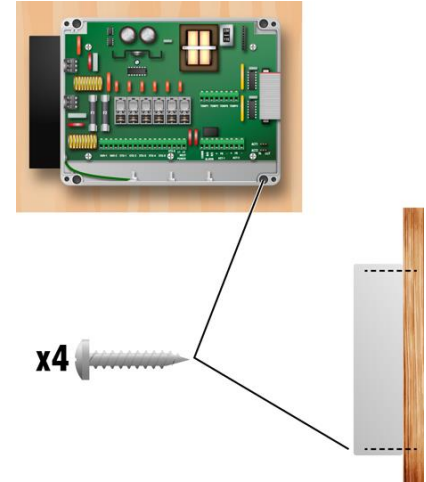

Connecting equipment to the Plus Touch

Follow these instructions when installing the Plus Touch and connecting equipment to it.



Use the electrical knockouts for bringing wires or cables into or out of the Plus Touch enclosure. Do not make additional holes in the enclosure; this can damage the watertight seal or control components and void the warranty.



- ◇ Plus Touch test modes are useful for testing your equipment after installing and configuring it. For more information, read **Testing sensors and equipment** on page 72.
- ◇ Refer to **Appendix C: Installation worksheet** on page 85 and **Appendix D: Configuration worksheets** on page 87 when installing equipment.

Connecting actuators

You can connect up to two actuators to a Plus Touch. Actuators are used for equipment that is not OFF or ON, but instead varies by a percentage. For example, inlets can be open various distances from 0 percent to 100 percent.

Linear actuators are usually connected directly to inlets, or using cables and pulleys. Inlets are generally located in the ceiling or walls. Inlet systems are usually spring loaded to aid in closing the inlet, or counter weighted to aid in opening the inlets.

Each actuator you connect requires two relays: one for opening, and one for closing. Actuators must be connected in the following combinations.

<p>Actuator 1:</p> <ul style="list-style-type: none"> Relay 1 – open Relay 2 – close 	<p>Actuator 2:</p> <ul style="list-style-type: none"> Relay 3 – open Relay 4 – close
---	---



Actuators can be connected to relay pairs 1 and 2 or 3 and 4 only. Actuators cannot be connected to any other combination of relays. For example, you cannot connect an actuator to relays 1 and 3.

In Plus Touch, actuators are considered “inlets with feedback”. If yours *does not* require feedback, it is considered a curtain, or, “inlet without feedback”. For more information, read **Configuring relays for inlet actuators or curtains** on page 34.

Feedback potentiometers

Each actuator you connect must have a feedback potentiometer. The feedback potentiometer, which you connect to one of the Plus Touch’ two corresponding feedback terminals, lets the control know how far the actuator’s arm is extended.

Most linear actuators are available with potentiometer feedback and internal adjustable limit switches. A 10,000 ohm, 10 turn feedback potentiometer is preferred, but the internal feedback potentiometer can range between 1000 and 20,000 ohms. Potentiometers outside of this range will affect the precision to which the Plus Touch can control the actuator.



- ◇ A system operates more precisely when using the largest amount of stroke that is feasible with the actuator. The stroke is the distance the actuator arm extends or retracts.
- ◇ If you are unsure of the potentiometer wiring for your actuator, read **Determining correct actuator feedback wiring** on page 83.
- ◇ When routing the actuator feedback wires, do not run them in or along the same conduit as AC-power lines. Follow the guidelines in the **Control fundamentals guide**.
- ◇ If you are measuring AC power with a digital multimeter (DMM), note that if a limit switch opens the circuit, the DMM measures voltage after the relay switch even if the relay is open.



The ratings of the actuator must not exceed the ratings of the Plus Touch.

Plus Touch relay ratings: 10 A at 120/230 VAC, general-purpose (resistive)
1/3 HP at 120 VAC, 1/2 HP at 230 VAC
360 W tungsten at 120 VAC

To connect actuators

Connect actuators to the Plus Touch as shown below. Refer to your actuator’s installation guide for information about its power supply requirements.

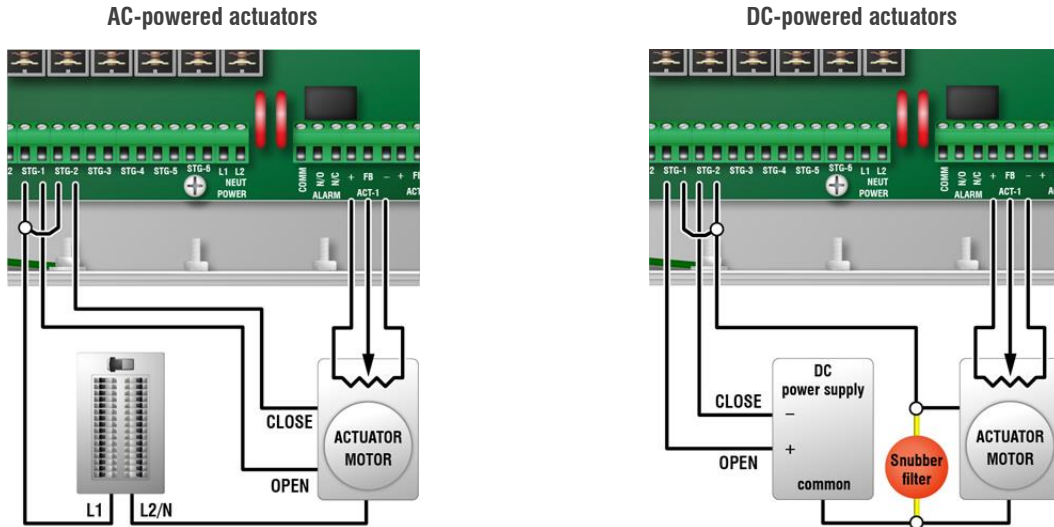

Connecting curtain machines

Curtains are usually controlled by equipment called curtain machines (sometimes referred to as winches). Curtains are opened and closed to let in more air or less air, the idea being more air cools the building.

You can connect up to two curtain machines to the Plus Touch. Each curtain machine you connect requires two relays: one for opening the curtain, and one for closing the curtain. Curtains must be connected in the following combinations.

Curtain 1:	Relay 1 – open Relay 2 – close	Curtain 2:	Relay 3 – open Relay 4 – close
------------	-----------------------------------	------------	-----------------------------------



In Plus Touch, curtains are considered “inlets without feedback”. If yours *does* require feedback, it is considered an actuator, or, “inlet with feedback”. For more information, read **Configuring relays for inlet actuators or curtains** on page 34.



The ratings of the equipment must not exceed the ratings of the Plus Touch relays.

Plus Touch relay ratings

- ◇ 10 A at 120/230 VAC, general-purpose (resistive)
- ◇ 1/3 HP at 120 VAC, 1/2 HP at 230 VAC
- ◇ 360 W tungsten at 120 VAC

To connect curtain machines

Connect curtain machines to the Plus Touch as shown.

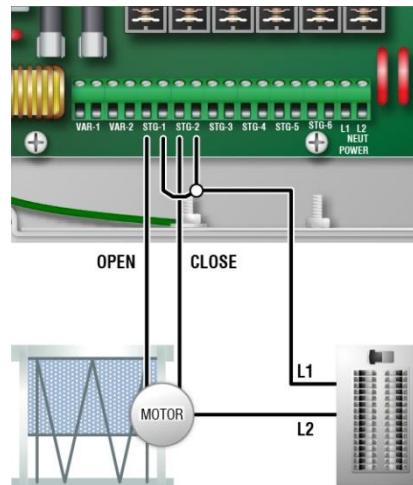

Connecting cooling, heating, and duty cycle equipment to relays

Heating or cooling equipment includes electric heaters, furnaces, single-speed fans, and any other equipment that is either on or off.

The ratings of the equipment must not exceed the ratings of the Plus Touch relays.

Plus Touch relay ratings: 10 A at 120/230 VAC, general-purpose (resistive)
 1/3 HP at 120 VAC, 1/2 HP at 230 VAC
 360 W tungsten at 120 VAC



Gas furnaces using hot-surface ignition or glow plug can draw more current than indicated on their nameplate and require power contactors. For more information, read your furnace dealer.

To connect equipment to relays

Connect equipment as shown below.

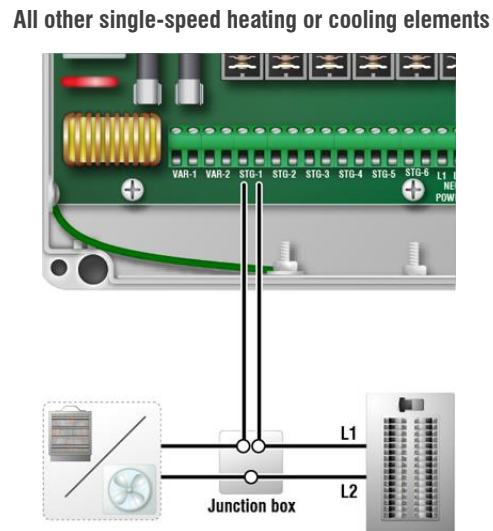
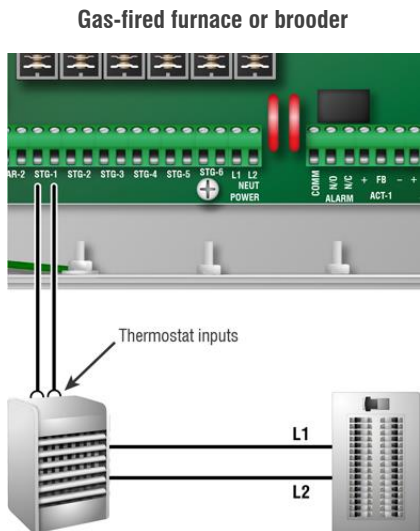

Connecting variable heating or cooling equipment

Variable cooling equipment includes equipment such as variable-speed fans. Variable heating equipment includes equipment such as heat mats and heat lamps.

- ◇ **Only permanent split capacitor motors appropriate for variable speed control, or shaded pole motors, can be used on the variable stages.**
- ◇ If you are using three-phase power, connect the Plus Touch and the variable cooling equipment to the same phase. For more information, read **Using three-phase power** on page 19.
- ◇ The ratings of the equipment must not exceed the ratings of the Plus Touch' variable stages.



Variable stage ratings

- ◇ 10 A at 120/230 VAC, general-purpose (resistive)
- ◇ 7 FLA at 120/230 VAC, PSC motor
- ◇ 1/2 HP at 120 VAC, 1 HP at 230 VAC, PSC motor

Variable stage fuses

- ◇ 15 A, 250 VAC ABC-type ceramic

To connect equipment to variable stages

Connect variable heating or cooling equipment to the Plus Touch as shown below.

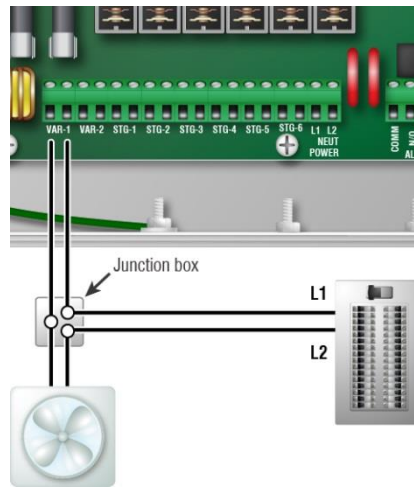

Using three-phase power

If you are connecting the Plus Touch to a three-phase system, make sure to connect the control power and the variable cooling equipment to the same phase.

The Plus Touch must be powered from the same phases that supply the equipment. If the Plus Touch power and the variable stages are wired to different phases, the equipment will operate erratically.

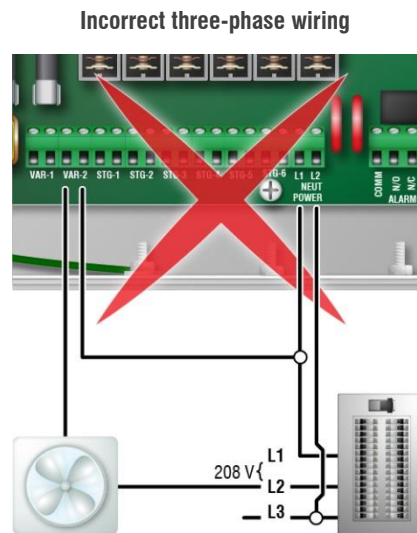
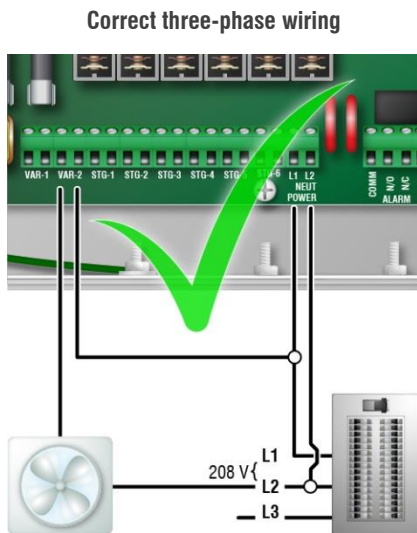

Connecting Phason 3K temperature sensors

Plus Touch has four zone-temperature sensor terminals, TEMP1 to TEMP4. You can connect any of Phason’s standard 3K temperature sensors to these terminals. All connected and enabled sensors are averaged to provide a more balanced temperature reading in the zone.

You can also connect a Phason 3K temperature sensor to the OUTDOOR terminal for monitoring outdoor temperatures.



- ◇ If there are no functioning temperature sensors, Plus Touch controls the equipment as if the master set point for the zone is the actual temperature.
- ◇ Replace damaged temperature sensors as soon as possible. If a temperature sensor is damaged, disable it until you can replace it with a new one.
- ◇ When routing the temperature sensor cables, do not run them in or along the same conduit as AC-power lines.



- ◇ You can extend sensor cables up to 500 feet. For more information, read the **Control Fundamentals** guide that came with your control.

To connect temperature sensors

Follow these guidelines and connect the temperature sensor as shown below.

- ◆ Do not run the sensor cable in the same conduit as AC power cables
- ◆ Do not run the sensor cable beside AC power cables or near electrical equipment.
- ◆ When crossing other cables or power lines, cross them at a 90-degree angle.

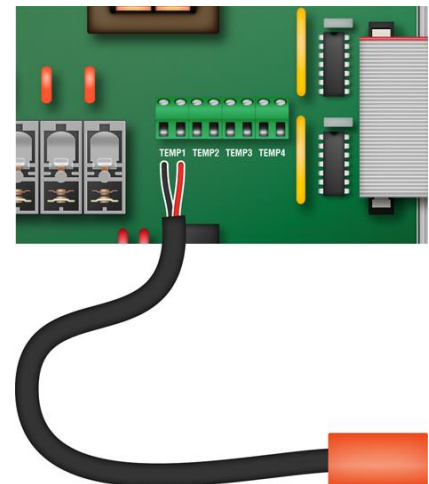

Connecting DOL sensors

Plus Touch gives you the ability to connect DOL 114 temperature and humidity, DOL 119 carbon dioxide, and DOL 53 ammonia sensors. Connecting the additional sensors gives you the ability to use modifiers that allow you to override settings when certain conditions are met, such as when carbon dioxide levels are too high. For more information, read **Programming modifiers** on page 43

To connect DOL 114 sensors

You can connect a DOL 114 sensor to the **TEMP/HUM** connectors as shown in the drawing.

1. Position the jumpers on the pins as shown.
2. Connect the wires from the DOL 114 sensor shown.

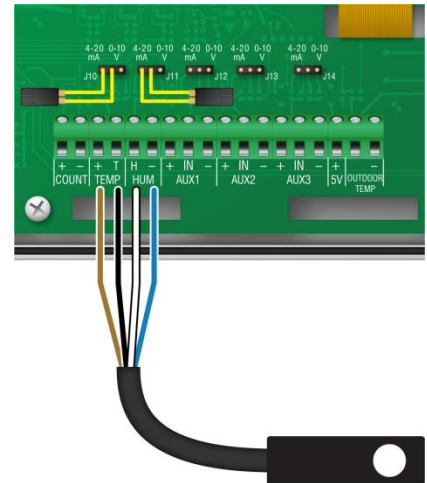

To connect DOL 119 sensors

You can connect a DOL 119 sensor to the any of the three **AUX** connectors.

1. Position the jumper on the pins as shown.
2. Connect the wires from the DOL 119 sensor shown.

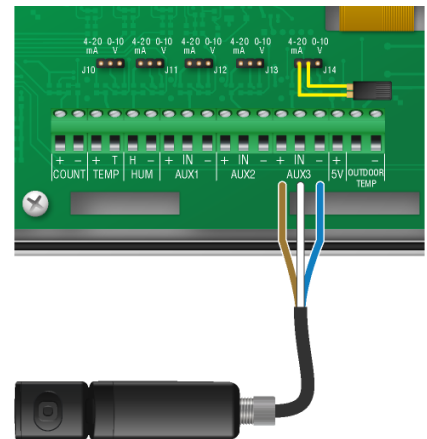

- ◇ The white wire is 10,000 ppm.
- ◇ The black wire (5000 ppm) is not supported.

To connect DOL 53 sensors

You can connect a DOL 53 sensor to the any of the three **AUX** connectors.

1. Position the jumper on the pins as shown.
2. Connect the wires from the DOL 53 sensor shown.

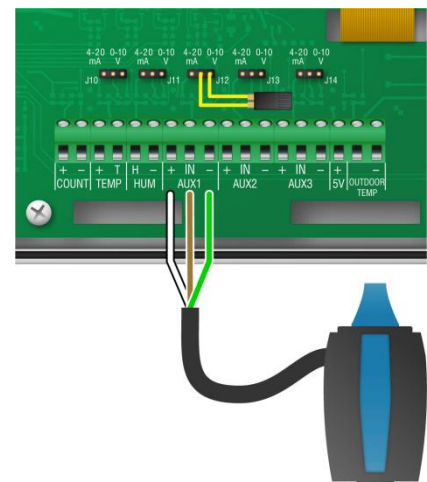

Connecting the power source



- ◇ Before connecting the incoming power, switch OFF the power at the source.
- ◇ Do not switch ON the power until you have finished all wiring and verified all equipment is properly connected and free of obstructions.



- ◇ Before connecting the power, set the voltage selection switch to the correct voltage.
- ◇ If you are using three-phase power, make sure the control power and the variable speed fans are connected to the same phase. For more information, read **Using three-phase power** on page 19.

You can connect the Plus Touch to 120 or 230 VAC, 50 or 60 Hz power.

To connect the incoming power source

1. Set the voltage select switch to the correct voltage setting.
2. Connect the incoming power source as shown below.

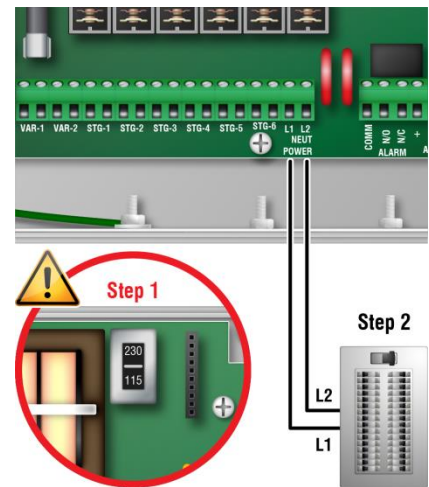

Finishing the installation

After installing and connecting equipment to the Plus Touch, you are ready to finish the installation. Before you start configuring the control, you need to verify the connections and configuration.

Make sure the configuration worksheets in **Appendix D** correspond to the way the equipment is connected to the Plus Touch. It is very important that the connections and the worksheets are the same, because the next step after closing the cover is to tell the Plus Touch which equipment is connected to each terminal. It is important so you can be sure you are controlling the equipment you think you are controlling.

1. Make sure all the wires are properly connected to the correct terminals.
2. Make sure the voltage selection switch is in the correct setting, 115 or 230 VAC.
3. Make sure the display cable is properly connected. For more information, read **Bottom layout** on page 12.
4. Place the cover on the control.
5. Switch on the power to the Plus Touch.
When you switch on the power to the Plus Touch, the display should show the status screen. If the display does not come on, go back to step 1. If the display shows an alarm message, read **Programming alarms** on page 45.
6. Insert the four screws into the cover and then tighten them.



Do not over tighten the screws. Avoid using power screwdrivers or drills.

Chapter 3: Configuring your Plus Touch

Chapter 3 explains how to configure the Plus Touch. Configuring the Plus Touch includes telling it which equipment is connected to each terminal.

- ◆ What you need to know before configuring below
- ◆ Configuring the main control functions on page 26
- ◆ Configuring equipment on page 32

What you need to know before configuring

Configuring the Plus Touch includes “telling” it what equipment it will control and how it will control that equipment. For example, the Plus Touch has six relay stages; you need to tell the stages if they will control actuators, fans, heaters, or something else.

Before you begin configuring the Plus Touch, make sure:

- ◆ It has power
- ◆ All equipment has been properly connected to the correct terminals.
- ◆ You know which equipment is connected to which variable stages and relays



This chapter does not explain set points, idle speeds, or other settings. For information about those settings, read **Chapter 4: Programming the Plus Touch** on page 37.

Configuration checklist

Because some items need to be configured before others, we recommend configuring the Plus Touch in following order.

Configuring main control functions

- Setting the clock
- Selecting the units of measure
- Configuring hysteresis
- Configuring relay stagger
- Configuring alarm silencing
- Configuring the zone control mode

Configuring variable stages and relays

- Configuring sensor inputs
- Configuring equipment (variable stages and relays)



- ◇ We recommend configuring **all** your equipment before programming the settings (temperature set points, idle speeds, and so on). Use the **Appendix D: Configuration worksheets** on page 87 to help you keep track of which equipment is connected to which relays and variable stages.
- ◇ Plus Touch built-in tests are useful for testing your equipment after installing and configuring it. For more information, read **Testing sensors and equipment** on page 72.

Configuring the main control functions

Setting the clock

The Plus Touch has a clock that keeps track of the time for the daily high and low temperatures and the growth curves. If there is a power failure, or you need to adjust for daylight savings time, you will have to change the clock.



Plus Touch starts counting time as soon as it is connected to an incoming power supply.

To set the clock

1. Press the **Menu** and then **Configuration**.
2. Press **Date and Time**.
3. To switch between 12 and 24 formats, select or deselect **24-Hour Time**.
4. Press the **Up** or **Down** arrows to adjust the date and time.
4. Press **Save**.

Selecting the units of measure

The Plus Touch displays temperatures in either degrees Fahrenheit (°F) or degrees Celsius (°C), but not both at the same time. The factory default is °F. If you want to change the temperature units, follow the steps below.



The unit of measure you select will not affect THI if you will be using it.

To select the units

1. Press **Menu** and then **Configuration**.
2. Press **Units**.
3. Select the units you want to use.
4. Press **Save**.

Configuring hysteresis

Hysteresis helps prevent damage to the relays, variable stages, and the equipment connected to them by preventing the stages from switching on and off rapidly when the temperature is hovering close to the set point.

Hysteresis is the number of degrees above the set point that a heating stage or relay switches off, and the number of degrees below the set point that a cooling stage or relay switches off. For example, a household thermostat might switch on a furnace at 68°F when the house is cooling down, but switch it off at 70°F when the house is warming up. The difference between these two values is the hysteresis.

There are separate hysteresis values for each zone. All equipment assigned to the zone is affected by the zone's hysteresis value.

Default: 1.0°F (0.5°C)

Range: 0.3 to 5.0°F (0.2 to 2.8°C)

To configure hysteresis

1. Press the **Menu** and then **Configuration**.
2. Press **Hysteresis**.
3. Press the **Up** or **Down** arrows to adjust the hysteresis value.
4. Press **Save**.

Configuring relay stagger

Relay stagger prevents several relays from switching on at the same time by offsetting each relay when the control starts. Inlet relays are not affected by relay stagger.

Let's say you have relays 1 and 2 configured for inlets; relays 3, 4, and 5 configured for cooling; and relay 6 configured for heating. The temperature is above the set point. This is what will happen when the control starts.

- ◆ Relays 1/2: not affected by relay stagger, switch on immediately
- ◆ Relay 3: switch on immediately
- ◆ Relay 4: switch on 5 seconds after relay 3
- ◆ Relay 5: switch on 5 seconds after relay 4
- ◆ Relay 6: remain off

Default: 5 seconds

Range: 0 to 59 seconds

To configure relay stagger

1. Press the **Menu** and then **Configuration**.
2. Press **Relay Stagger**.
3. Press the **Up** or **Down** arrows to change stagger duration.
4. Press **Save**.

Configuring alarm silencing

Alarm silencing is the amount of time an alarm is temporarily disabled (silenced) after it has been acknowledged. Alarm silencing prevents the alarm relay from triggering immediately if it has been acknowledged when the alarm condition is still present. If the alarm condition is still present after the silencing duration, the alarm triggers again.

Default: 15 minutes

Range: 1 to 240 minutes (4 hours)

To configure alarm silencing

1. Press the **Menu** and then **Configuration**.
2. Press **Alarm Silencing**.
3. Press the **Up** or **Down** arrows to change the alarm silencing variation.
4. Press **Save**.

Configuring the zone control mode

There are three zone control modes: staged, merged, and THI. Staged and merged are described below, THI mode is described in the next section.

Staged mode

Staged mode is the traditional ventilation mode that uses “stages” of variable or on/off equipment. As the temperature increases, stages increase speed or switch on in sequence to increase ventilation and cool the room.

Staged mode uses a master set point and individual equipment set points. A master set point is the desired or target temperature for a zone. When you adjust the master set point, the equipment set points are automatically adjusted by the same amount.

You can use a growth curve and/or a minimum ventilation curve in staged mode.

Merged mode

Merged mode uses steps. Each step has a temperature range and an output range for the equipment that operates during the step. As the temperature increases, ventilation equipment increases speed, switches on, or opens to increase ventilation and cool the room. One of the benefits of merged mode is that it can provide smoother transitions between steps than staged mode can between stages.

Merged mode can have up to four steps. Each step has a temperature range and an output range for the equipment that operates during the step.



- ◇ You can use a growth curve in merged mode, but you cannot use a minimum ventilation curve.



- ◇ For information about growth curves, read **Programming growth curve** on page 39.
 - ◇ From information about minimum ventilation curves, read **Programming minimum ventilation curve** on page 41.
-

To configure zone control

1. Press the **Menu** and then **Configuration**.
2. Press **Zone Control Mode**.
3. For each zone you are configuring, choose **Staged mode**, **Merged mode**, or **THI mode**.
4. If you will be using a growth curve and/or minimum ventilation curve (staged only), press the checkbox beside that option.
5. Press **Save**.

Using THI for zone control

THI mode is like staged mode except that it controls equipment according to THI values. As THI increases, stages increase speed or switch on in sequence to increase ventilation and cool the room.

THI mode uses a master set point and individual equipment set points. A master set point is the desired or target THI for a zone. When you adjust the master set point, the equipment set points are automatically adjusted by the same amount.

You can use a growth curve and/or a minimum ventilation curve in THI mode.



- ◇ THI requires a humidity sensor installed and enabled.

Configuring sensor inputs

Plus Touch supports the following sensors connected to the specified inputs. Other sensors are not supported.

Input	Location	Sensor types	Zone control	Influencer
TEMP1 to 4	Bottom	Phason 3K	YES	YES
TEMP HUM	Cover	DOL114 Temperature and Humidity Sensor	TEMP – YES HUM – NO	YES
AUX1 AUX2 AUX2	Cover	DOL119 Carbon Dioxide (CO2) DOL53 Ammonia Sensor (NH3)	NO	YES
OUTDOOR	Cover	Phason 3K	NO	YES
COUNT	Cover	--- Not supported ---	---	---

For the exact location of the sensor inputs, see the diagrams on pages 12 and 13.

Temperature averaging and zone control

If you have more than one temperature sensor assigned to control a zone, Plus Touch automatically averages the temperature readings it receives. Temperature averaging provides a more balanced, overall temperature for a zone.



- ◇ If there are no functioning temperature sensors, Plus Touch controls the equipment as if the master set point for the zone is the actual temperature.
- ◇ Replace damaged temperature sensors as soon as possible. If a temperature sensor is damaged, disable it until you can replace it with a new one.

Modifiers

Modifiers are sensors that can modify zone control. For example, you can use a humidity sensor to modify ventilation and increase ventilation when humidity levels are too high. For more information, read **Programming modifiers** on page 43.

To configure inputs

1. Press the **Menu** and then **Configuration**.
2. Press **Sensors**.
3. Press the type of input you want to configure.
4. Press the input you want to configure.
The Sensor Configuration screen displays.

- ◆ **Name:**
 - a) Press the name button and then press **Rename**.
 - b) Press **Reset** and then type the new name.
 - c) When finished, press **Confirm** to save the name and return to the previous screen.
- ◆ **Function:**
Press the function button. If there only one option available, it will be enabled. If there is more than one option available, select the one you want from the list.
- ◆ **Control zones:**
Sensors connected to inputs TEMP 1-4 on the bottom board or TEMP on the display board can be used to control zones. Other inputs will not display this option. Select each zone the sensor will control.
- ◆ **Influence zones:**
All sensors can be used to influence control zones. If the sensor will influence zones, select the zones.

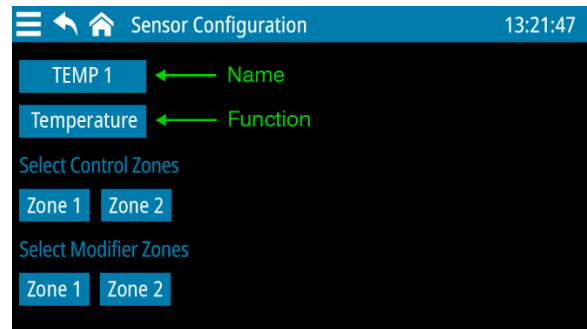
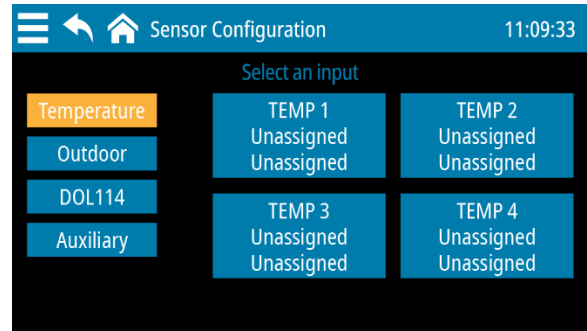

5. Press **Save** when you are finished.

Configuring equipment

Configuring variable stages

The Plus Touch has two variable AC stages (**VAC 1** and **VAC 2**) to control equipment using gradually increasing or decreasing voltage. Variable stages can be cooling or heating.

- ◆ **Cooling:** the stage controls cooling equipment, such as a variable speed fan.
- ◆ **Heating:** the stage controls heating equipment, such as a heat lamp.

To configure variable stages

1. Press the **Menu** and then **Configuration**.
2. Press **Equipment**.
3. Press **VACs**.
4. Press the variable stage you want to configure. The Equipment Configuration screen displays.

◆ **Name:**

- a) Press the name button and then press **Rename**.
- b) Press **Reset** and then type the new name.
- c) When finished, press **Confirm** to save the name and return to the previous screen.

◆ **Function:**

Press the function button and then choose the equipment type. If you choose cooling, motor curve and de-icing options become available.

◆ **Motor curve:**

The default is motor curve 1. Change the motor curve *only if you need to*. Read **Motor curves** on page 96 before changing the motor curve.

To change the curve, press the button and then select one of the other ones.

◆ **De-icing:**

To enable de-icing, press the checkbox beside it. Press the Up or Down arrows to adjust the setting.

◆ **Zone:**

Press the zone button and then choose the one the equipment will operate in.

5. Press **Save** when you are finished.

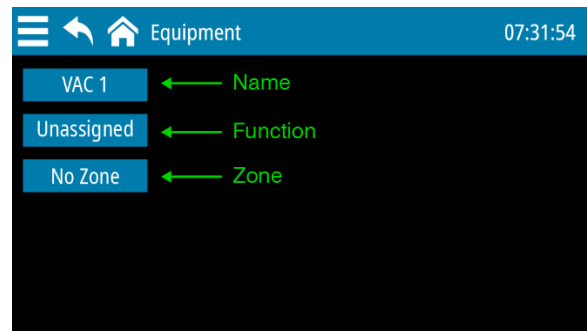
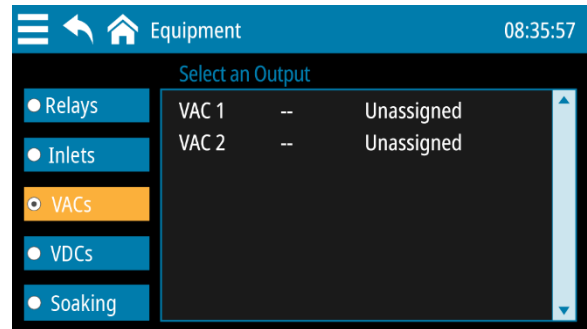

Configuring relays

Plus Touch has six relays that can be configured for any of the following functions:

- ◆ **Unassigned:** the relay is always open/off. This is the default.
- ◆ **Cooling:** the relay controls cooling equipment, such as a fan, and switches on when temperatures are above the set point.
- ◆ **Cooling duty cycle:** the relay controls cooling equipment and switches on and then off for specified durations when temperatures are above the set point.
- ◆ **Heating:** the relay controls heating equipment, such as an electric heater, and switches on when temperatures are below the set point.
- ◆ **Heating duty cycle:** the relay controls heating equipment and switches on and then off for specified durations when temperatures are below the set point.
- ◆ **Inlet with feedback:** the relay controls a motor that opens and closes and requires feedback to know its position. This configuration requires two relays, one for open and one for close. An example is an actuator.
- ◆ **Inlet without feedback:** the relay controls a motor that opens and closes, but does not require feedback. This configuration requires two relays, one for open and one for close. An example is a curtain machine.
- ◆ **Relay or variable follower:** the relay controls equipment that is on when a selected output (relay or variable stage) is on, and off when that selected output is off.
- ◆ **Timed event:** the relay switches equipment on or off at scheduled times each day.



- ◇ For inlet and curtain machine configuration, see page 34.
- ◇ For soaking and other evaporative cooling configuration, see page 36.

To configure relays

1. Press the **Menu** and then **Configuration**.
2. Press **Equipment**.
3. Press **Relays**.

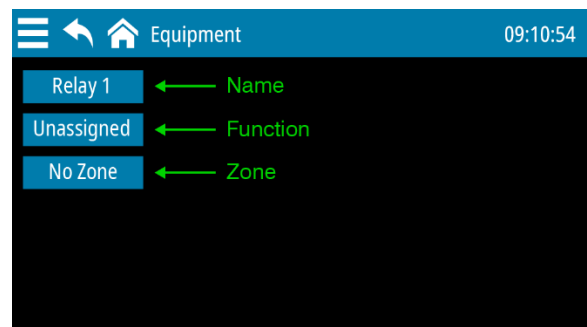
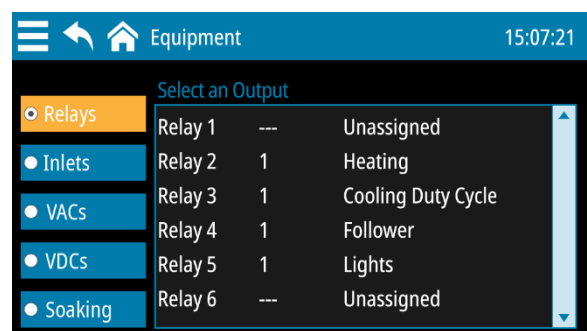

4. Press the relay you want to configure.
The Equipment screen displays.
 - ◆ **Name:**
 - a) Press the name button and then press **Rename**.
 - b) Press **Reset** and then type the new name.
 - c) When finished, press **Confirm** to save the name and return to the previous screen.
 - ◆ **Function:**
Press the function button and then choose the equipment type. If you choose “relay follower” or “variable follower”, you will need to press **Following** and then choose the output that the relay will follow.
 - ◆ **Zone:**
Press the zone button and then choose the one the equipment will operate in.
5. Press **Save** when you are finished.

Configuring relays for inlet actuators or curtains

Inlets, curtains, and similar equipment are opened and closed to let in more air or less air. The idea is that more air cools the building. There are two types of inlets: inlets with feedback and inlets without feedback. Each requires one relay for opening and one for closing.

Inlets with feedback

The relays control a motor that opens and closes and requires feedback to know its position. An example is an actuator. You can configure up to two inlets that require feedback.

Inlets without feedback

The relays control a motor that opens and closes, but does not require feedback. An example is a curtain machine or winch. You can configure up to six inlets that do not require feedback.



- ◇ Inlet 1 uses relay 1 to open and relay 2 to close the inlet. Inlet 2 uses relay 3 to open and relay 4 to close.
- ◇ You configure one of the relay pairs, Plus Touch automatically configures the other. For example, if you configure relay 1 for inlet 1, relay 2 will be automatically configured.



- ◇ Use the **Relay configuration worksheet** on page 89 when configuring relays.
-

To configure relays for inlets

1. Press the **Menu** and then **Configuration**.
2. Press **Equipment**.
3. Press **Inlets**.
4. Press the inlet you want to configure.
The Equipment Configuration screen displays.

- ◆ **Name:**
 - a) Press the name button and then press **Rename**.
 - b) Press **Reset** and then type the new name.
 - c) When finished, press **Confirm** to save the name and return to the previous screen.
- ◆ **Function:**
Press the function button and then choose the equipment type. If you choose “with feedback”, the **Calibrate Actuator** button will display. For more information, read **Calibrating inlet actuators** below.

- ◆ **Zone:**
Press the zone button and then choose the one the equipment will operate in.

- ◆ **Relays:**
Press the **Left** or **Right** arrows below Open Relay and Close Relay to choose a relay for each.

5. Press **Save** when you are finished.

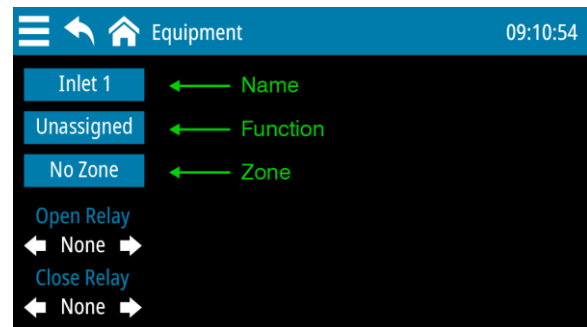
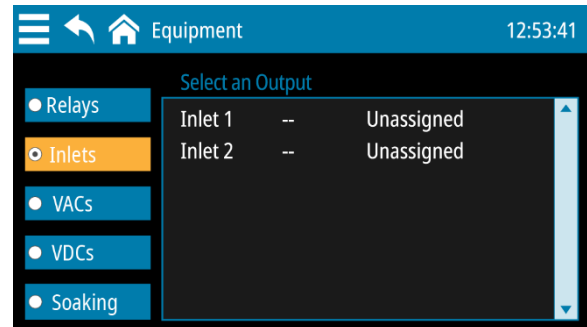

Calibrating inlet actuators

After you configure relays for inlet actuators, you need to calibrate the actuators. Calibrating the actuator lets the control know the position of the actuator when it is fully extended and fully retracted. Plus Touch uses the limits to define the range of motion it uses to position the inlets. The limits tell the control how much to adjust when you want the inlets open 25 percent, for example.

During calibration, the actuator opens, pauses, and then closes. If the actuator is operating properly, the inlet should open completely and then close completely. After closing completely, the actuators should position according to the temperature and default settings.



- ◇ Before calibrating actuators, make sure the limit switches are set and the cable and counter weights can move freely.
- ◇ If calibration stops after closing the first time or fails to position properly, the feedback signal is not connected correctly. Verify the potentiometer wiring. For more information, read **Determining correct actuator feedback wiring** on page 83.
- ◇ Because cables can stretch and equipment can come out of alignment, we recommend you reset the limit switches and calibrate your actuators at least once each year.

To calibrate inlet actuators

1. At the **Status** screen, press the widget for the actuator you want to calibrate.
2. Press **Calibrate**.
3. Press **Yes** to start calibration or **No** to cancel.
If you started calibration, the actuator should open all the way and then close all the way. If calibration is successful, the actuator will move into position according to its settings.

Configuring evaporative cooling

Each of the two zones on the Plus Touch has an evaporative cooling “group” available. Evaporative cooling refers to any type of soaking, misting, fogging, or sprinkling. Plus Touch has six relays you can configure to control a combination of solenoids, pumps, and fans for evaporative cooling.

- ◆ **Soakers:** The relay controls solenoids for soaking, misting, or fogging nozzles.
- ◆ **Pumps:** The relay controls water pumps for supplying water to the soakers.
- ◆ **Fans:** The relay controls fixed-stage fans that operate during the cooling cycle

To configure evaporative cooling

1. Press the **Menu** and then **Configuration**.
2. Press **Equipment**.
3. Press **Soaking**.
4. Press the zone you want to configure.
The Soaking Zone screen displays. Soakers is selected by default.
5. Press **Select Relay** to select the first soaker relay.
Repeat this step for each soaker relay.
6. Repeat step 5 for pumps and fans.
7. Press **Save** when you are finished.

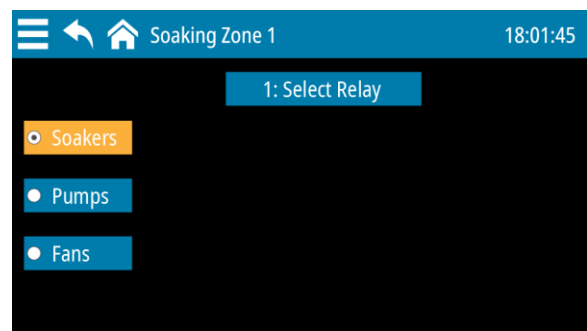
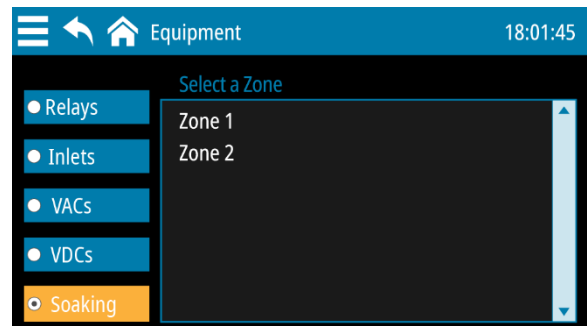

If you configure multiple relays for soakers, they switch on during the cycle in the sequence they are listed in the configuration screen. If you configure multiple soakers for pumps or fans, each of them switches on at the same time.

Chapter 4: Programming the Plus Touch

- ◆ **Programming zone settings** on page 38
- ◆ **Programming equipment settings** on page 47

Before you program the Plus Touch

Programming your Plus Touch means “telling” the equipment what you want it to do and when you want it done. For example, for a single-speed fan set for cooling, you might say “Switch on when the temperature reaches 80°F.”

Programming checklist

Because some settings must be programmed before others, we recommend you program the Plus Touch in the following order. If you do not have equipment of a particular type, for example, curtains, skip that step.

Programming zone settings

- Programming the master set point
- Programming growth curve
- Programming minimum ventilation curves
- Programming modifiers
- Programming alarms

Programming equipment settings

- | | | |
|--|-----------|--|
| <input type="checkbox"/> Staged ventilation | <i>OR</i> | <input type="checkbox"/> Merged ventilation |
| <input type="checkbox"/> Programming variable cooling stages | | <input type="checkbox"/> Programming merged ventilation |
| <input type="checkbox"/> Programming inlet actuators | | |
| <input type="checkbox"/> Programming curtain control relays | | |
| <input type="checkbox"/> Programming relay stages | | |
| <input type="checkbox"/> Programming duty cycles | | |
| <input type="checkbox"/> Soaking (evaporative cooling) | | <input type="checkbox"/> Heating |
| <input type="checkbox"/> Programming evaporative cooling | | <input type="checkbox"/> Programming variable heating stages |
| <input type="checkbox"/> Timed events | | <input type="checkbox"/> Programming duty cycles |
| <input type="checkbox"/> Programming timed events | | |

Before you program the Plus Touch, make sure:

- ◆ All equipment has been properly connected to the correct terminals
 - ◆ You know which equipment is connected to variable stages, relays, and sensor inputs
 - ◆ All variable and relay stages have been properly configured and tested
- For more information, read **Chapter 3: Configuring your Plus Touch** on page 25.



Use **Appendix E: Settings worksheets** on page 90 when programming the Plus Touch.

Programming zone settings

- ◆ Master set point (below)
- ◆ Growth curves (on page 39)
- ◆ Minimum ventilation curves (on page 41)
- ◆ Modifiers (on page 43)
- ◆ Alarms (on page 45)

Programming the master set point

A master set point is the target or desired temperature or THI for the zone. This is the value that will be tracked by the individual stages. The individual set points for each variable and relay stage will be adjusted relative to the master set point for that zone. **Make sure you set the master set point before setting the individual set points.**

For example, say the master set point for zone 1 is 80°F, a variable-stage fan set point is 5 degrees higher (85°F), and a single-stage heater set point is 7 degrees lower (73°F). If you lower the master set point to by 5 degrees to 75°F, the set points for the fan and heater will also be lowered by 5 degrees: to 80°F and 68°F.

The master set point does not change until you change it, or until an enabled growth curve adjusts it.

To program the master set point

1. Press the **Menu** and then **Settings**.
2. Press **Master Set Point**.
3. Below *Zone*, press the **Left** or **Right** arrow to choose the zone.
4. Below *Set Point*, press the **Up** or **Down** arrows to set the master set point for the zone.
5. Press **Save** when you are finished.

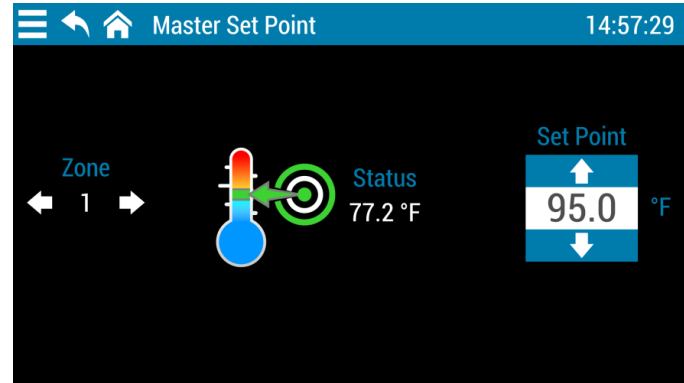

You can also get the master set point from the status screen.

Programming growth curves

A growth curve is an extension of the master set point concept. The growth curve automatically adjusts the temperature or THI set points over time. For example, in hog production, newborn piglets require a high temperature for comfort and health. As they grow older, they need a steadily lower temperature. Using the growth curve, Plus Touch automatically adjusts the temperatures.

You can have up to seven steps in a growth curve. Each step has a start date and temperature. Plus Touch automatically calculates the set points for the days between the steps and adjusts the set points at midnight each day. Individual set points for the variable and fixed stages are adjusted relative to the growth curve temperature. Growth curves are an extremely powerful feature because they help you put fan and heating strategies in place once, and then adjust them automatically over time.

Step	Temperature (°F)	Duration (days)
1	88.0	5
2	86.5	10
3	85.0	10
4	83.5	10
5	81.0	5
6	78.0	5
7	74.0	10

For example, in the table on the right, the duration of step 2 is 10 days. The difference between the starting set point (86.5°F) and the starting set point for the next step (85°F) is 1.5°F.

Plus Touch divides the temperature difference by the duration, $1.5 \div 10 = 0.15$, and then automatically adjusts the set point by 0.15°F each day for 10 days.

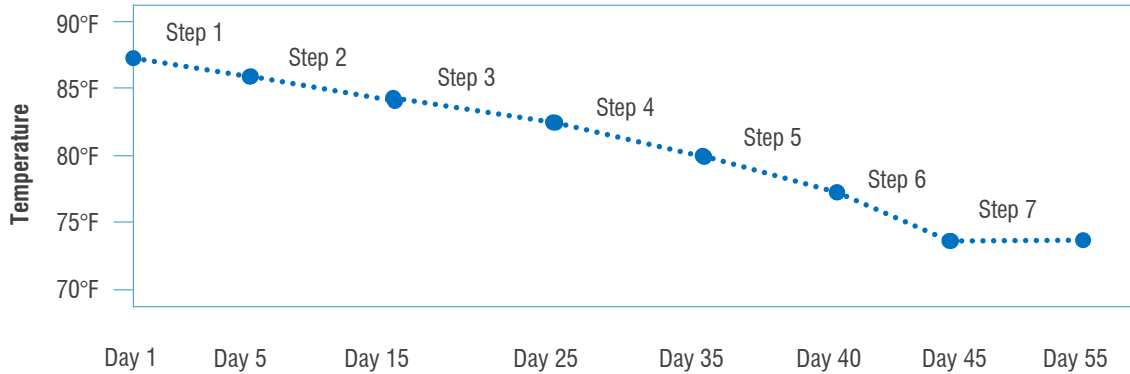

Use the **Growth curve worksheet** on page 90 when programming growth curves.



- ◇ If you have a growth curve controlling the zone, you cannot adjust the master set point.
- ◇ The growth curve resets at the **beginning** of the restart day.

☰ ← 🏠 Growth Curve - Zone 1 14:57:29

Step Start Day							Zone		
↑	↑	↑	↑	↑	↑	↑	←	1	→
1	5	15	25	40	60	90	Current Day		
↓	↓	↓	↓	↓	↓	↓	←	100	→
Temperature (°F)							Restart Day		
↑	↑	↑	↑	↑	↑	↑	↑		
20	25	30	35	40	45	50	110		
↓	↓	↓	↓	↓	↓	↓	↓		

To program growth curves

1. Press the **Menu** and then **Settings**.
2. Press **Staged Ventilation**.
3. Press **Ventilation Curve**.
4. Below *Zone*, press the **Left** or **Right** arrow to choose the zone.
5. Below *Step Start Day*, press the **Up** or **Down** arrows to set the start day for each step.
6. Below *Restart Day*, press the **Left** or **Right** arrow to choose the zone.
7. Below *Temperature*, press the **Up** or **Down** arrows to set the master set point for the start day of each step.
8. Press **Save** when you are finished.

To change the current day

1. Press the **Menu** and then **Settings**.
2. Press **Staged Ventilation**.
3. Press **Ventilation Curve**.
4. Below *Current Day*, press the **Left** or **Right** arrow to change the day.
5. Press **Save** when you are finished.

Programming minimum ventilation curves

Minimum ventilation is very important for controlling humidity and getting rid of gases such as carbon dioxide and ammonia. Insufficient ventilation can cause high humidity, high gas levels, and stagnant air. As animals grow older, they require more fresh air but produce more humidity and gases. Using a minimum ventilation curve, you can have Plus Touch automatically adjust the minimum ventilation as the animals grow.



- ◇ The minimum ventilation curve affects only the first variable stage that is configured as cooling for the zone.
- ◇ If you are using a minimum ventilation curve you cannot adjust the idle speed in the variable stage settings.

How ventilation curves work

Plus Touch reads the curve each day at midnight changes the idle speed setting for the current day. At the end of the curve, the control continues using the settings from the last day of the curve.

The minimum ventilation curve affects only the first variable stage that is configured as cooling for the zone. The following examples show which variable stage would be affected by the minimum ventilation curve in different situations.

Example 1

VAC 1 - Cool **Controlled by curve**
 VAC 2 - Cool Not controlled

Example 2

VAC 1 - Heat Not controlled
 VAC 2 - Cool **Controlled by curve**

Example 3

VAC 1 - Unused Not controlled
 VAC 2 - Unused Not controlled
 VDC 1 - Unused Not controlled
 VDC 2 - Cool **Controlled by curve**
 VDC 3 - Heat Not controlled
 VDC 4 - Unused Not controlled

Curve length and current day

Curve length is the number of days in the curve. Curves can have up to 365 days. Current day defines which day's settings Plus Touch is using.

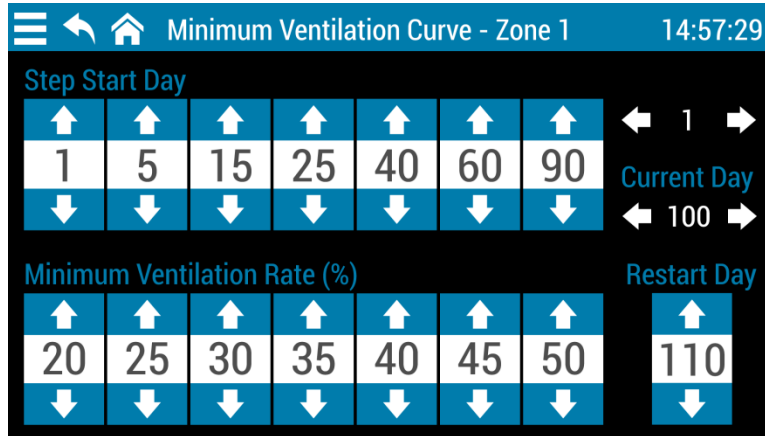

To program minimum ventilation curves

1. Press the **Menu** and then **Settings**.
2. Press **Staged Ventilation**.
3. Press **Ventilation Curve**.
4. Below *Zone*, press the **Left** or **Right** arrow to choose the zone.
5. Below *Step Start Day*, press the **Up** or **Down** arrows to set the start day for each step.
6. Below *Restart Day*, press the **Left** or **Right** arrow to choose the zone.
7. Below *Minimum Ventilation Rate*, press the **Up** or **Down** arrows to set the idle speed for the start day of each step.
8. Press **Save** when you are finished.



Before you can set the current day, you must configure the zone to use the minimum ventilation curve. For more information, read **Configuring the zone control mode** on page 29.

To change the current day

1. Press the **Menu** and then **Settings**.
2. Press **Staged Ventilation**.
3. Press **Ventilation Curve**.
4. Below *Current Day*, press the **Left** or **Right** arrow to change the day.
5. Press **Save** when you are finished.

Programming modifiers

Modifiers, sometimes called influencers, allow you to override equipment settings when certain conditions are met, regardless of temperature or THI. You can have up to three modifiers for each variable stage or relay.

Type and sensor

Type can be either a zone reading or sensor reading. Zone reading is the average temperature of all temperature sensors configured for the zone. If you have other sensors configured as modifiers for the zone, for example CO₂ (carbon dioxide) or NH₃ (ammonia), you can choose one of those types.

If you select a type of sensor and there is more than one sensor of that type, you need to select the specific sensor you want to use.



You must have a sensor configured to modify equipment settings in the zone before you can select it as a modifying sensor. For more information, read **Configuring sensor inputs** on page 30.

Modifier modes

Set value modifiers set a variable stage or relay to a specific value or state when a condition is met. For example, “When the humidity is over 90%, switch on a fan.”

Influence modifiers (variable only) adjust the output of a variable stage proportionally over a range of values. The adjustment can be an increase or decrease.

For example, let's say a CO₂ modifier starts at 2500 ppm and ends at 3500 ppm; the starting adjustment is +10 and ending is +40. When the CO₂ is 2500, the modifier increases the output by 10%. As the CO₂ rises, the modifier increases in the output proportionally until the CO₂ is 3500 ppm and the output +40%.

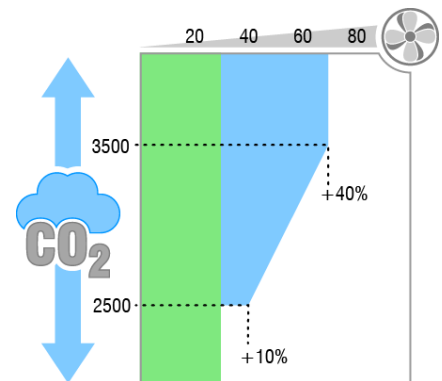

And With Next modifiers must meet two conditions before setting or adjusting the output. For example, “When the temperature is over 80°F and the humidity is over 90%, switch on a fan.”

To view modifiers

- ◆ Press the left or right arrow beside *Output* to view or choose which variable stage or relay you want to modify.
- ◆ If you have two or three modifiers for an output, press the left or right arrow beside *Modifier* to view them.

To program “set value” or “and with next” modifiers

1. Press the **Menu** and then **Settings**.
2. Press **Modifiers**.
3. Press the **Left** or **Right** arrows beside *Output* and *Modifier* to choose the output and modifier you want to program.
4. Press the button beside *Mode* and then select *Set Value*.
5. Press the button beside *Type* and then select one of the sensor types. If you have more than one of the above types of sensors, beside *Sensor*, press the button and then select the specific sensor.
6. Press the < or > below *Comparison* to choose whether you want to modify when the sensor reading is less than or greater than the value.
7. Press **Up** or **Down** below *Value* to set the value to which the sensor reading will be compared.
8. If you are programming a “set value” modifier, press the **Up** or **Down** arrows beside *Set Output* to set the output the stage or relay will be at while modified.
9. Press **Save** when you are finished.

To program “influence” modifiers

Influence modifiers are for variable stages only.

1. Press the **Menu** and then **Settings**.
2. Press **Modifiers**.
3. Press the **Left** or **Right** arrows beside *Output* and *Modifier* to choose the output and modifier you want to program.
4. Press the button beside *Mode* and then select *Set Value*.
5. Press the button beside *Type* and then select one of the sensor types. If you have more than one of the above types of sensors, beside *Sensor*, press the button and then select the specific sensor.
6. Press the **Up** or **Down** arrows below *Start At* and *End At* to set the range of values within which the stage or relay will be modified.
7. Press the **Up** or **Down** arrows below *Starting Output* to set the output at the beginning of the influence range, and *Ending Output* to set the output at the end of the influence range.
8. Press **Save** when you are finished.

To remove modifiers

1. Press the **Menu** and then **Settings**.
2. Press **Modifiers**.
3. Press the **Left** or **Right** arrows beside *Output* and *Modifier* to choose the output and modifier you want to remove.
4. Press **Clear Modifier**.
5. Press **Save** when you are finished.

Programming alarms

An alarm occurs if an enabled alarm condition is present for longer than the minimum duration of one minute. The one-minute minimum duration prevents alarms from occurring when the temperature or THI rises or drops for just a few seconds. The exception to the one minute minimum is actuator jam alarms. Actuator jam alarms activate 20 seconds after the alarm is detected.

When an alarm occurs, the alarm relay triggers (switches) and a message flashes on the screen. For more information, read **Acknowledging alarms** on page 72.

The actuator jam alarm has no settings, but you can enable or disable it.

Temperature example

If the high temperature alarm setting is 85.0°F and the temperature rises to 86 degrees, but drops below 85 degrees 30 seconds later (before the minimum duration of 1 minute), there is no alarm.

If the temperature rises to 86 degrees and stays there for 1 minute, an alarm occurs. The alarm relay remains active until the temperature drops below the high temperature alarm setting.

Outdoor temperature compensation

The purpose of outdoor temperature compensation is to prevent high temperature or THI alarms from occurring on hot days when the set point cannot be maintained. Outdoor temperature compensation is available for zones only, not individual sensors, and requires a temperature sensor that is mounted outdoors.

Outdoor compensation is the offset added to the high alarm setting when the outdoor temperature is higher than the high alarm setting. High maximum is the highest temperature you can have in the zone; any temperature above this value is an alarm condition. Note that the high maximum is the **outside temperature**. Therefore, if you are using THI, the high maximum will still be a temperature.

You set the compensation offset and the high maximum values. Plus Touch adds the compensation offset to the outdoor temperature to create a new setting called the *compensated high alarm*. The compensated high alarm becomes the new limit, up until the high maximum. When the zone temperature is higher than the compensated high alarm, there is an alarm condition.

In the following example, the high alarm is 75°F, compensation offset is 5°F, and high maximum is 85°F. Plus Touch adds 5° to the outdoor temperature to create the compensated high alarm, up to a maximum of 85°F.

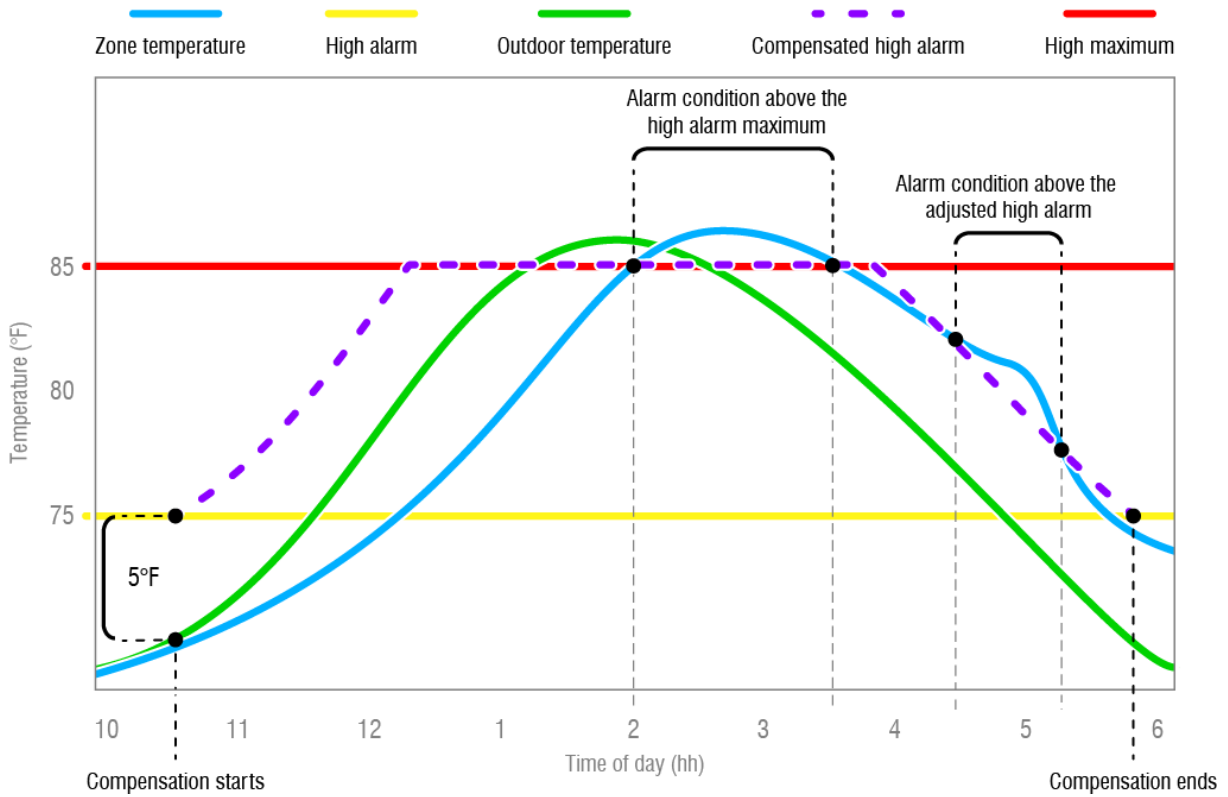

- ◆ At 10:30 AM, temperature compensation starts because the outdoor temperature plus the compensation offset is higher than the high temperature alarm setting.
- ◆ At 2:00 PM, there is an alarm condition because the zone temperature exceeds the high alarm maximum.
- ◆ 4:30 PM, there is an alarm condition because the room temperature exceeds the compensated high alarm.
- ◆ 5:45 PM, compensation ends because the outdoor temperature plus the compensation offset is less than the high temperature alarm setting.



Use the **Alarm settings worksheet** on page 95 when programming alarms. The worksheet contains descriptions of each setting.

Alarms 14:57:29

Zone	High Alarm	Compensation Offset
← 1 →	Enable <input checked="" type="checkbox"/>	Enable <input checked="" type="checkbox"/>
	90.0 °F	5.0 °F
	Low Alarm	High Maximum
Status <input checked="" type="checkbox"/> No Alarm	60.0 °F	98.0 °F

To enable or disable alarms

1. Press the **Menu** and then **Settings**.
2. Press **Alarms**.
3. Below *Zone*, press the **Left** or **Right** arrow to choose the zone, sensor, or equipment you want.
4. To enable or disable an alarm, press the **Enable** box beside the one you want to enable. There is a check in the box when enabled
5. Press **Save** when you are finished.

To program zone alarms

1. Press the **Menu** and then **Settings**.
2. Press **Alarms**.
3. Below *Zone*, press the **Left** or **Right** arrow to choose the zone, sensor, or equipment you want.
4. Press the **Up** or **Down** arrows to adjust the set points (except for actuator jam alarms).
5. To enable or disable an alarm, press the **Enable** box beside the one you want to enable. There is a check in the box when enabled
6. Press **Save** when you are finished.

Programming equipment settings

Programming the stages means entering the settings such as set points, idle speeds, ON/OFF times and durations, and so on.

Staged ventilation	Merged ventilation	Evaporative cooling
Variable stages (on page 49)	Merged ventilation (on page 48)	Soaking, misting, fogging, or sprinkling (on page 58)
Relays		
<ul style="list-style-type: none"> ◇ Actuators (on page 53) ◇ Curtains (on page 54) ◇ Relay stages (on page 56) ◇ Duty cycles (on page 56) 	<p style="margin: 0;">Heating</p> <hr style="border: 0.5px solid black;"/> <ul style="list-style-type: none"> Variable stages (on page 51) Relay stages (on page 56) Duty cycles (on page 58) 	<p style="margin: 0;">Other</p> <hr style="border: 0.5px solid black;"/> <ul style="list-style-type: none"> Timed events (on page 67)

Programming merged ventilation

Merged mode uses up to four steps. Each step has a temperature range for the equipment that operates during the step. Each type of ventilation equipment has its own settings for each step. One of the benefits of merged mode is that it can provide smoother transitions between steps than staged mode can between stages.

The following example includes two variable stages, one fixed stage, and inlets.

Steps	Set points		Variables				Fixed	Inlets	
	Start Temperature	End Temperature	VAR 24in		VAR 36in		F18 State	Actuator	
			Start Output	End Output	Start Output	End Output		Start Position	End Position
1	68	72	30	80	0	0	OFF	25	40
2	72	75	50	100	20	50	OFF	40	60
3	75	80	100	100	0	50	ON	60	80
4	80	85	100	100	50	100	ON	80	100

Each step's start and end temperatures define the range of the step. The equipment columns (variables, fixed, and inlets) show the settings during the step.

As the temperature rises or falls within a step, the speed of variables and position of inlets will increase or decrease proportionally; fixed stages will be at their assigned state. When the temperature rises above or falls below the range for a step, Plus Touch uses the next step. In the example above, when the temperature is 74.5°F, Plus Touch uses step 2. When the temperature rises over 75°F, the control uses step 3.

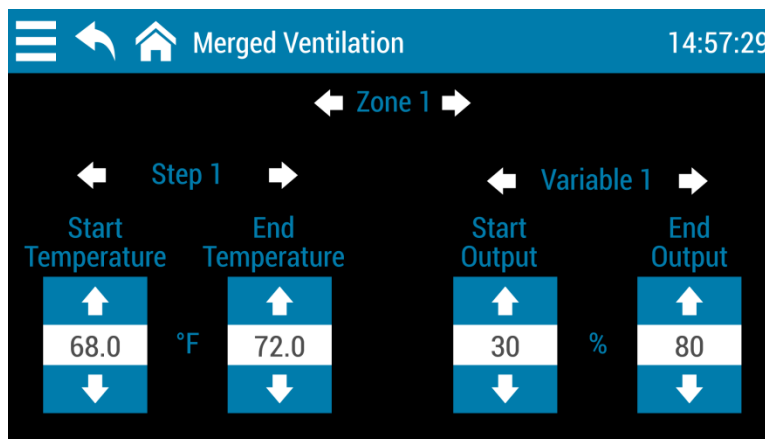

- ◇ You must have the zone configured for merged ventilation to program it.
- ◇ You can use a growth curve in merged mode, but you cannot use a minimum ventilation curve.
- ◇ The set points for merged ventilation cannot be lower than the master set point or growth curve (if configured to use growth curve). Program the master set point or growth curve before you program merged ventilation.



Programming variable cooling stages

Before programming the variable stages, make sure you have properly configured them. For more information, read **Configuring variable stages** on page 32.

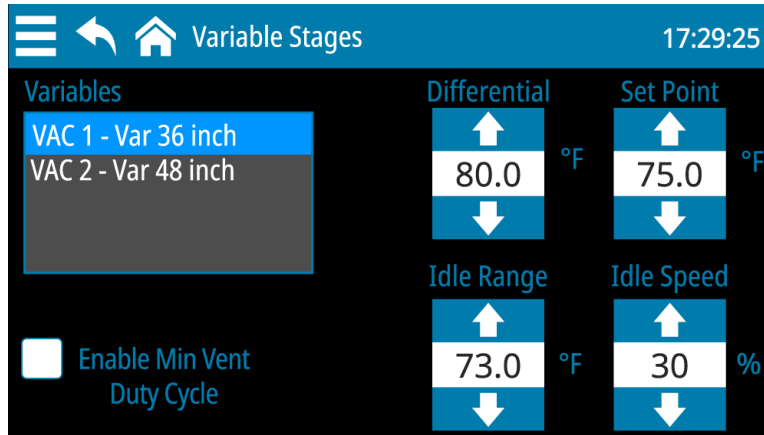

How variable stage cooling works

- ◆ When the temperature or THI is below the **idle range** value, the fan is off.
- ◆ When the temperature or THI reaches the **idle range** value, the fan runs at the **idle speed**. The fan continues to run at the **idle speed** until the temperature or THI rises to the **set point** value.
- ◆ When the temperature or THI is between the **set point** and **on differential** values, fan speed increases or decreases proportionally with the temperature or THI.
- ◆ When the temperature or THI is at or above the **differential** value, the fan runs at full speed.

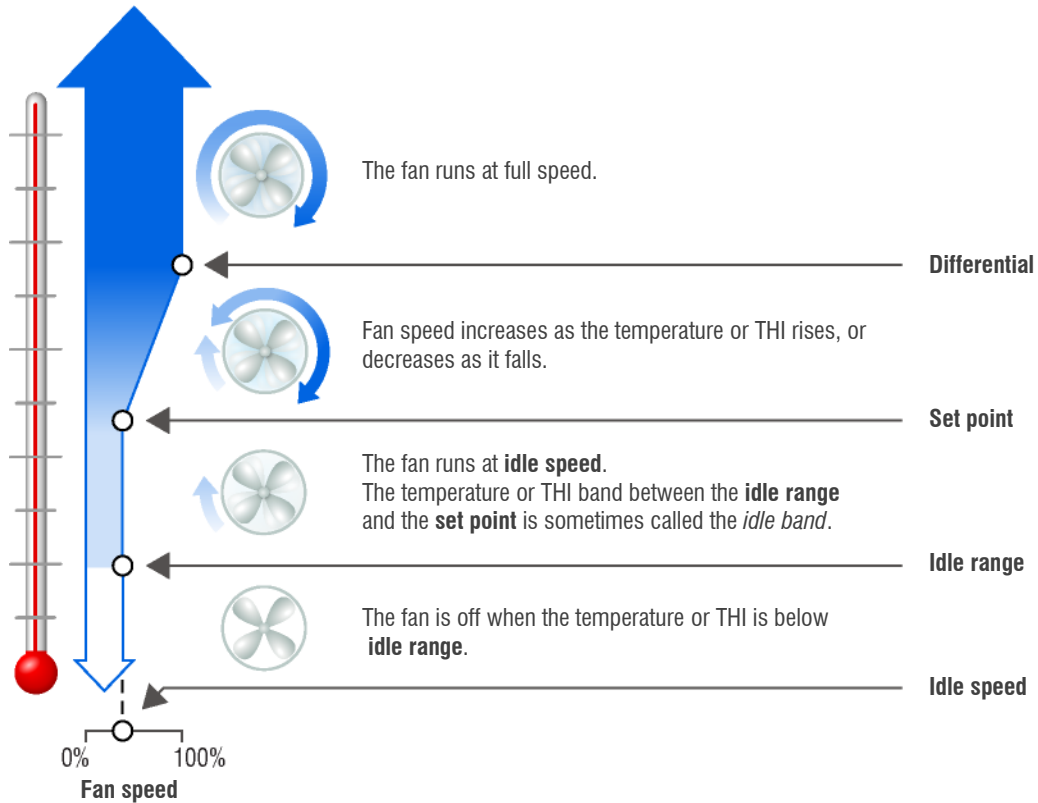

Use the **Variable stage settings worksheet** on page 91 when programming variable stages.

To program variable stages for ventilation

1. Press the **Menu** and then **Settings**.
2. Press **Staged Ventilation**.
3. Press **Variable Stages**
4. Press stage you want to program.
5. Press the **Up** or **Down** arrows to each of the settings.
6. Press **Save** when you are finished.

Programming variable heating stages

Before setting up the variable stages, make sure you have properly configured them. For more information, read **Configuring variable stages** on page 32.

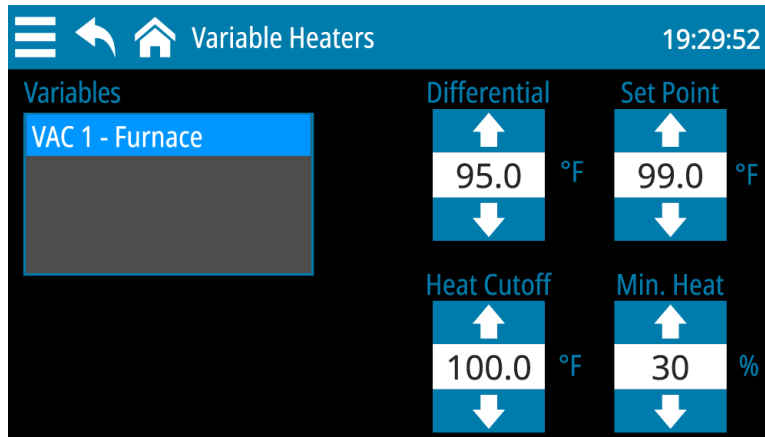

How variable heating stages work

- ◆ When the temperature or THI is above the **heat cutoff** value, the heater is off.
- ◆ When the temperature or THI drops below the **heat cutoff** value, the heater is at the **minimum heat**. The heater operates at **minimum heat** until the temperature or THI drops to the **set point**.
- ◆ When the temperature or THI is between the **set point** and the **differential** values, heater output increases or decreases proportionally with the temperature or THI.
- ◆ When the temperature or THI is below the **differential** value, the heater is at full output.

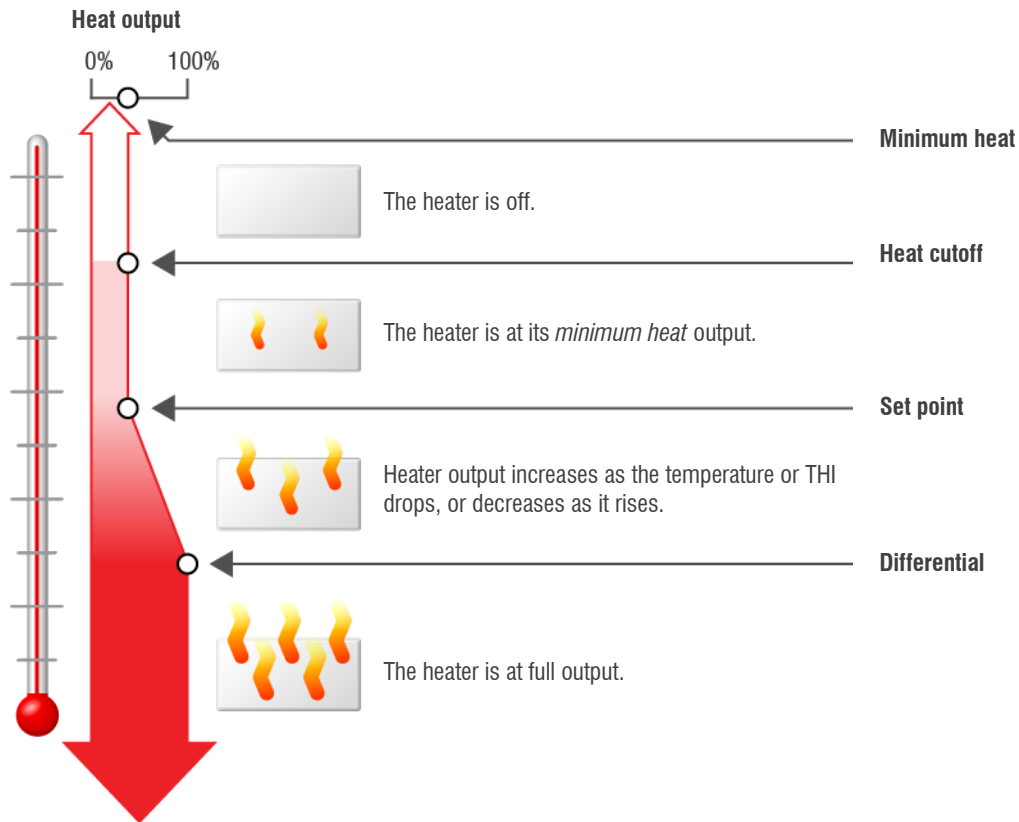

Use the **Variable stage settings worksheet** on page 91 when programming variable stages.

To program variable stages for heating

1. Press the **Menu** and then **Settings**.
2. Press **Heating**.
3. Press **Variable Stages**
4. Press stage you want to program.
5. Press the **Up** or **Down** arrows to each of the settings.
6. Press **Save** when you are finished.

Programming inlet actuators

Before programming the inlet actuator relays, make sure you have properly configured the relays and calibrated the actuators. For more information, read **Configuring relays for inlet actuators or curtains** on page 34 and **Calibrating inlet actuators** on page 35.

How inlets work

- ◆ When the temperature or THI is below the minimum set point, the inlet is closed.
- ◆ When the temperature or THI rises to the minimum set point, the inlet moves to the minimum position.
- ◆ As the temperature or THI rises, the inlet moves through the stages until it reaches its maximum open position. This method lets you gradually open inlets instead of fully opening them when the temperature or THI rises above a single set point.

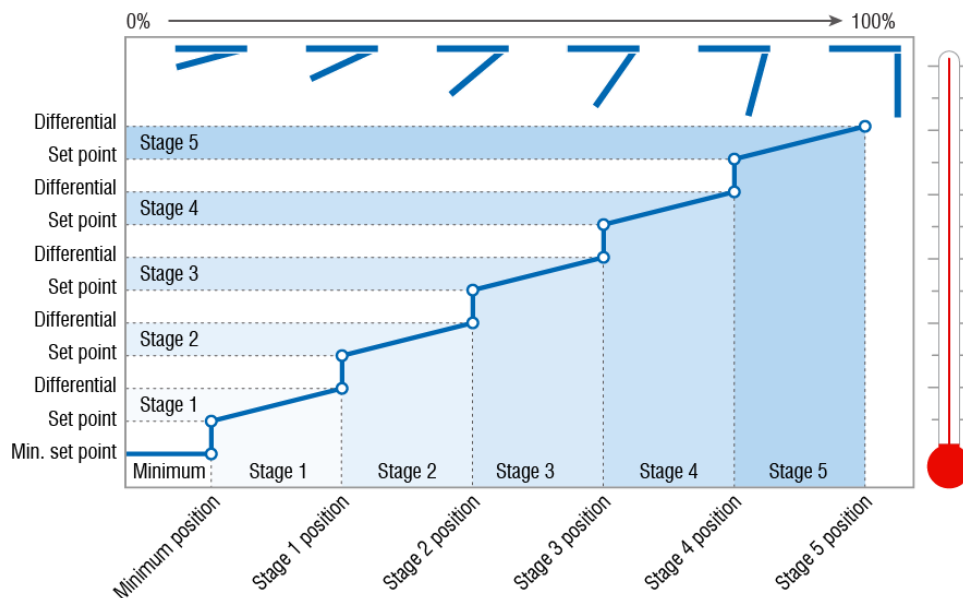

For example, you might decide to have the inlet open to 40 percent at stage 1, 60 percent at stage 2, 80 percent at stage 3, 90 percent at stage 4, and 100 percent at stage 5.

However, you don't want the inlet to open directly to 40 percent. That is why there are two temperature settings for each stage. The first setting is the stage set point. This is where the inlet starts opening. The second setting is the differential. This is where the inlet reaches the stage position.



- ◇ Use actuator control for actuators or curtain machines **only if they have feedback**. Using actuator control for motors without feedback can burn them out.
- ◇ For information about programming actuators or curtain machines without potentiometers, read **Programming curtain control relays** on page 54.

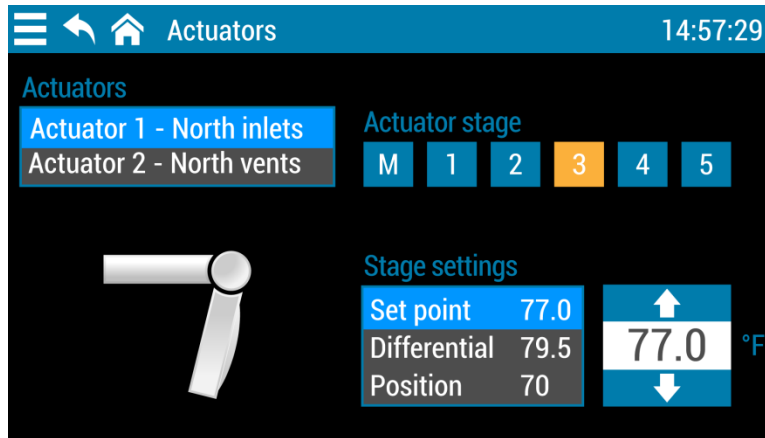

To program inlet actuators

1. Press the **Menu** and then **Settings**.
2. Press **Staged Ventilation**.
3. Press **Actuators**
4. Press the actuator and stage you want to program. It is best to program them in order, from minimum to 5.
5. Press **Set point** and then the **Up** or **Down** arrows to adjust the setting. Repeat this step for each setting.
6. Press **Save** when you are finished.

Programming curtain control relays

Curtains control the temperature or THI by adjusting air flow into the facility, with the idea that more air cools the building.

How curtains work

Curtains hold their position while the temperature or THI is within the **idle band** of the **set point**. For example, if the **set point** is 80°F and the **idle band** is 4°F (+2°/-2°), the curtain holds its position when the temperature is between 78°F and 82°F.

If the temperature or THI rises above the **idle band** (above 82°F in our example), the curtain opens for the **open run duration**. After opening, the curtain holds its position for the **open idle duration**. If the temperature or THI is still above the **idle band**, the curtain again opens for the **open run duration** and the process repeats.

If the temperature or THI drops below the **idle band** (below 78°F in our example), the curtain closes for the **close run duration**. After closing, the curtain holds its position for the **close idle duration**. If the temperature or THI is still below the **idle band**, the curtain again closes for the **close run duration** and the process repeats.

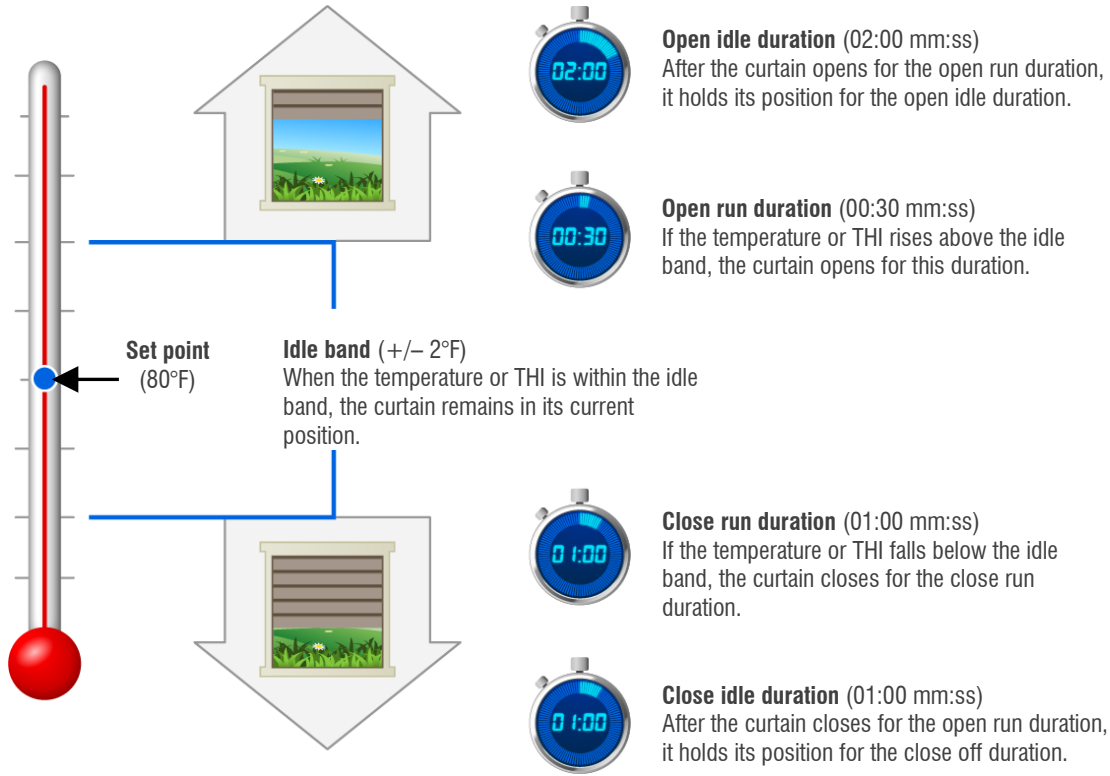

Use the **Curtain worksheet** on page 93 when setting up curtains.

To program curtain machines

1. Press the **Menu** and then **Settings**.
2. Press **Staged Ventilation**.
3. Press **Curtains**
4. Press the curtain you want to program.
The common settings (set point and idle band) and the closing settings (run duration and idle duration) display.
5. Press the **Up** or **Down** arrows to adjust each of the common and closing settings.
6. Press **Opening**.
7. Press the **Up** or **Down** arrows to adjust each of the opening settings.
8. Press **Save** when you are finished.

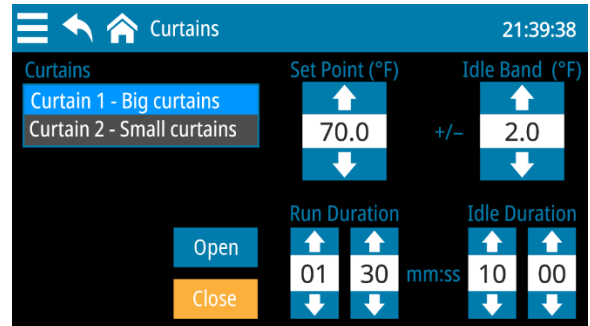

Programming relay stages

Programming relay stages means setting temperature or THI set points for relays to control equipment for ventilation or heating.



- ◇ Before programming relay stages, make sure you have properly configured the relays. For more information, read **Configuring relays** on page 33.
- ◇ Use the **Heating, cooling, and duty cycle relay worksheet** on page 93 when setting up heating and cooling equipment.

To program relays for cooling

1. Press the **Menu** and then **Settings**.
2. Press **Staged Ventilation**.
3. Press **Relay Stages**.
4. Press the relay you want to program.
5. Press the **Up** or **Down** arrows to adjust the set point.
6. Press **Save** when you are finished.

To program relays for heating

1. Press the **Menu** and then **Settings**.
2. Press **Heating**.
3. Press **Staged Heat**.
4. Press the relay you want to program.
5. Press the **Up** or **Down** arrows to adjust the set point.
6. Press **Save** when you are finished.

Programming duty cycles

A duty cycle switches equipment on and then off for specific durations, consistently repeating the process.

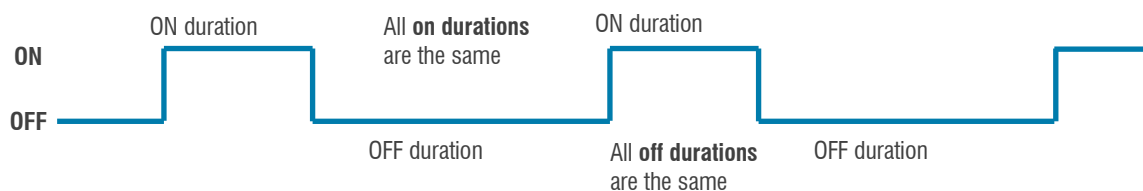

There are three types of duty cycles: **temperature-based**, **time-based**, and **persistent**.

Temperature-based (also for THI)

A temperature-based duty cycle has an **on duration**, an **off duration**, and a **set point**. A temperature-based duty cycle operates when the temperature or THI is above the **set point** for cooling, and below the **set point** for heating.

For cooling, the equipment switches on for the **on duration** and then off for the **off duration** only when the temperature or THI is above the **set point**. For a heating duty cycle, equipment switches on and off only when the temperature or THI is below the **set point**.

Time-based

A time-based duty cycle has an **on duration**, an **off duration**, a **start time**, and a **stop time**. A time-based duty cycle operates equipment only during defined times of the day. For example, you can have a duty cycle that is on for 5 minutes and then off for 10 minutes between 8 AM and 5 PM.

Persistent

A persistent duty cycle has an **on duration** and an **off duration**. A persistent duty cycle operates equipment at all times and conditions.



- ◇ Before programming relay stages, make sure you have properly configured the relays. For more information, read **Configuring relays** on page 33.
- ◇ Use the **Heating, cooling, and duty cycle relay worksheet** on page 93 when setting up heating and cooling equipment.

To program cooling duty cycles

1. Press the **Menu** and then **Settings**.
2. Press **Staged Ventilation**.
3. Press **Duty Cycles**.
4. Press the relay you want to program.
5. Press type of duty cycle you want. The displayed settings change depending which duty cycle you select.
6. Press the **Up** or **Down** arrows to adjust the settings.
7. Press **Save** when you are finished.

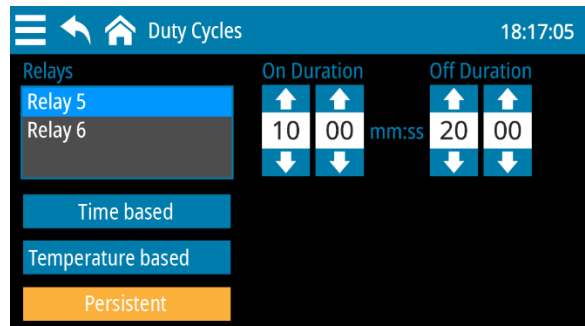
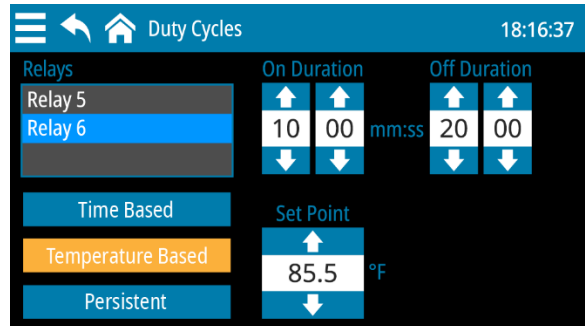
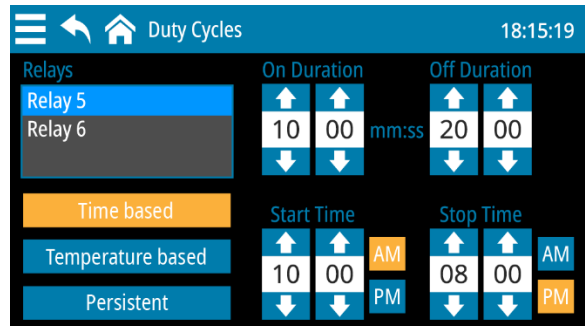

To program heating duty cycles

1. Press the **Menu** and then **Settings**.
2. Press **Heating**.
3. Press **Duty Cycles**.
4. Press the relay you want to program.
5. Press type of duty cycle you want.
The displayed settings change depending which duty cycle you select.
6. Press the **Up** or **Down** arrows to adjust each of the settings.
7. Press **Save** when you are finished.

Programming evaporative cooling

There are three misting modes: **soaking**, **misting/fogging**, and **smart**. Each mode has some common and some different settings.

Soaking mode

In soaking mode, the cycle duration decreases as the temperature or THI increases; soaking duration stays the same. Here is an example using temperature.

- ◆ When the temperature is below the low set point, no cooling cycle occurs.
- ◆ When the temperature is between the low and high set points, a cooling cycle occurs and the cycle duration is at the maximum. In our example, this is 16 minutes.
- ◆ When the temperature is between the high and maximum set points, the cycle duration is somewhere between the minimum and maximum durations. See point A on the graph.
- ◆ When the temperature is above the maximum set point, the cycle duration is at minimum.

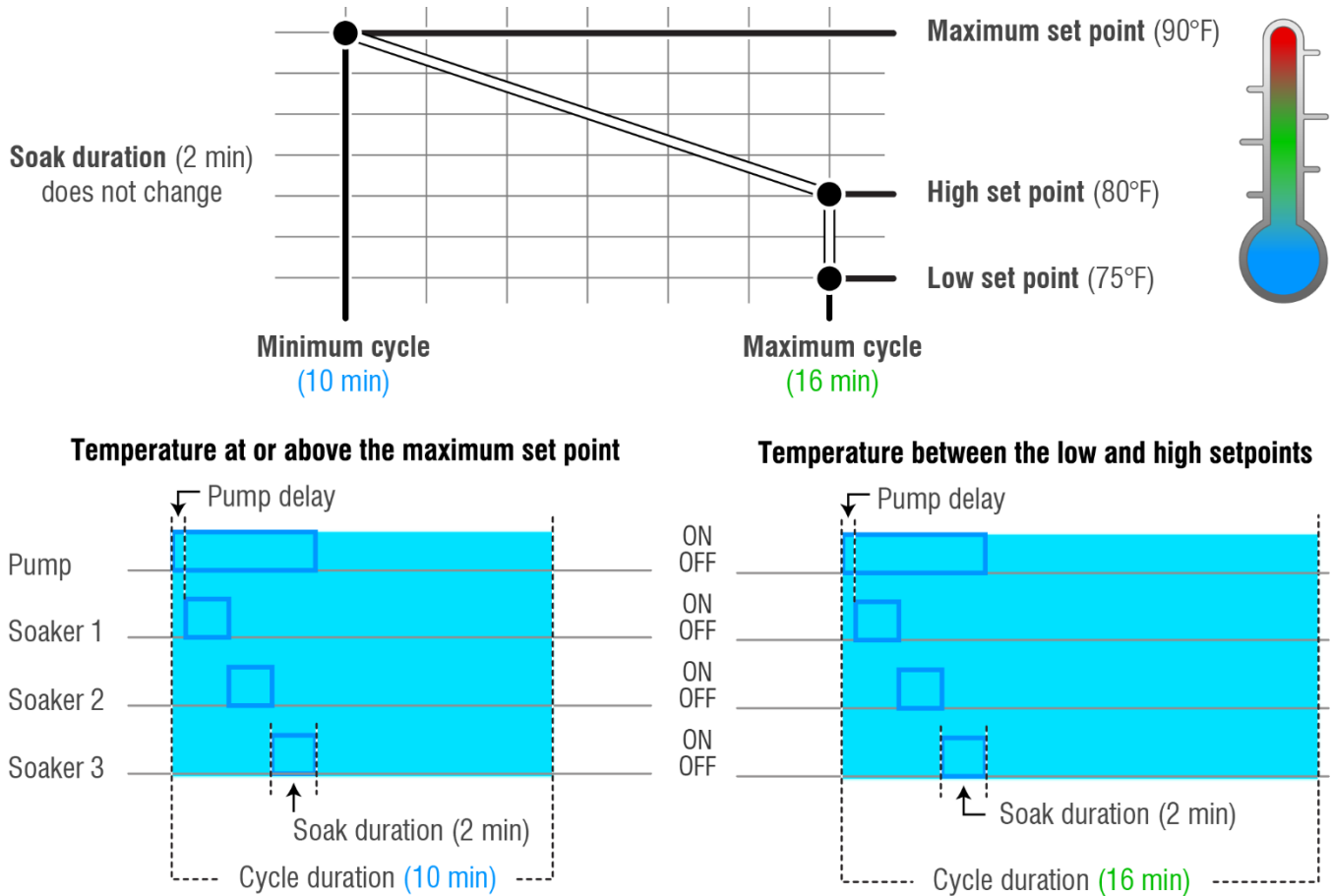

For a description of all evaporative cooling settings, read **Evaporative cooling settings** on page 65.

To use soaking mode

1. Press the **Menu** and then **Settings**.
2. Press **Soaking**.
The Soaking Settings screen displays, with the **Settings** button selected.
3. Press the box under Mode and then select *Soaking* to switch to soaking mode.
The screen will change to look like the one on the right.
4. Adjust the pump delay and active time range by pressing the **Up** or **Down** arrows.
5. Press **Save** when you are finished.

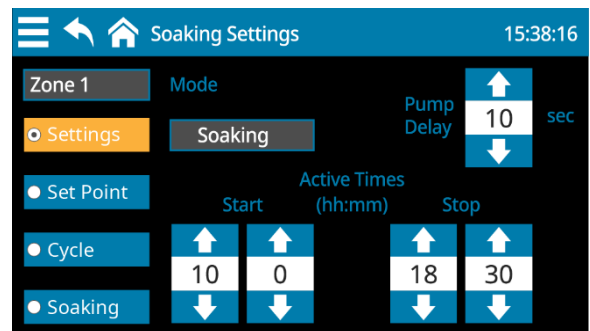

On this screen, you can enter the pump delay and active time range for soaking mode.

To adjust soaking mode temperature or THI set points

1. Press the **Menu** and then **Settings**.
2. Press **Soaking**.
The Soaking Settings screen displays, with the **Settings** button selected.
3. Press **Set Point**.
The screen will change to look like the one on the right.
4. Adjust the set points by pressing the **Up** or **Down** arrows.
5. To use humidity cutoff:
 - a. Select *Humidity Cutoff*.
 - b. Select a humidity sensor that is installed and enabled.
 - c. Adjust the cutoff value.
6. Press **Save** when you are finished.

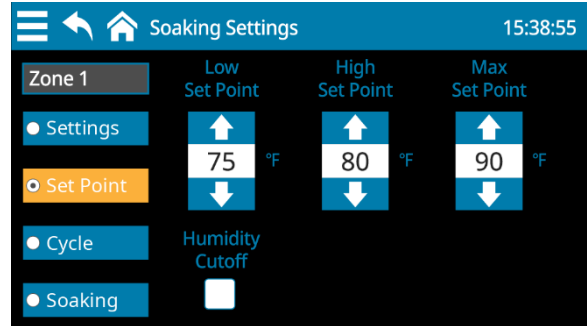

For information about humidity cutoff, read **Humidity cutoff** on page 66.

To adjust soaking mode cycle durations

1. Press the **Menu** and then **Settings**.
2. Press **Soaking**.
The Soaking Settings screen displays, with the **Settings** button selected.
3. Press **Cycle**.
The screen will change to look like the one on the right.
4. Adjust the minimum and maximum cycle durations by pressing the **Up** or **Down** arrows.
5. Press **Save** when you are finished.

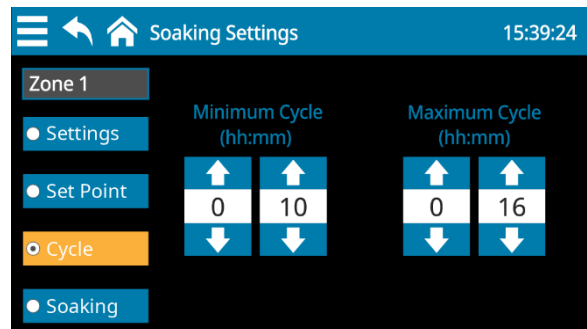

To adjust soaking mode soak duration

1. Press the **Menu** and then **Settings**.
2. Press **Soaking**.
The Soaking Settings screen displays, with the **Settings** button selected.
3. Press **Soaking**.
The screen will change to look like the one on the right.
4. Adjust setting by pressing the **Up** or **Down** arrows.
5. Press **Save** when you are finished.

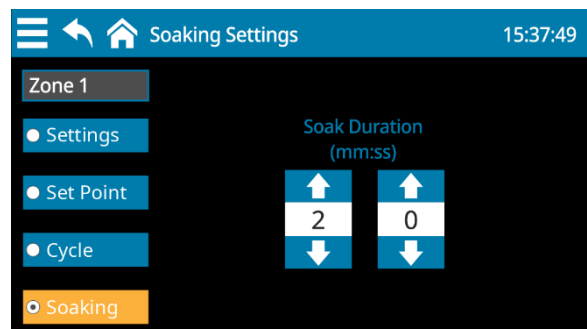

Misting/fogging mode

In misting/fogging mode, the misting duration increases as the temperature or THI increases; cycle duration stays the same. Here is an example using temperature.

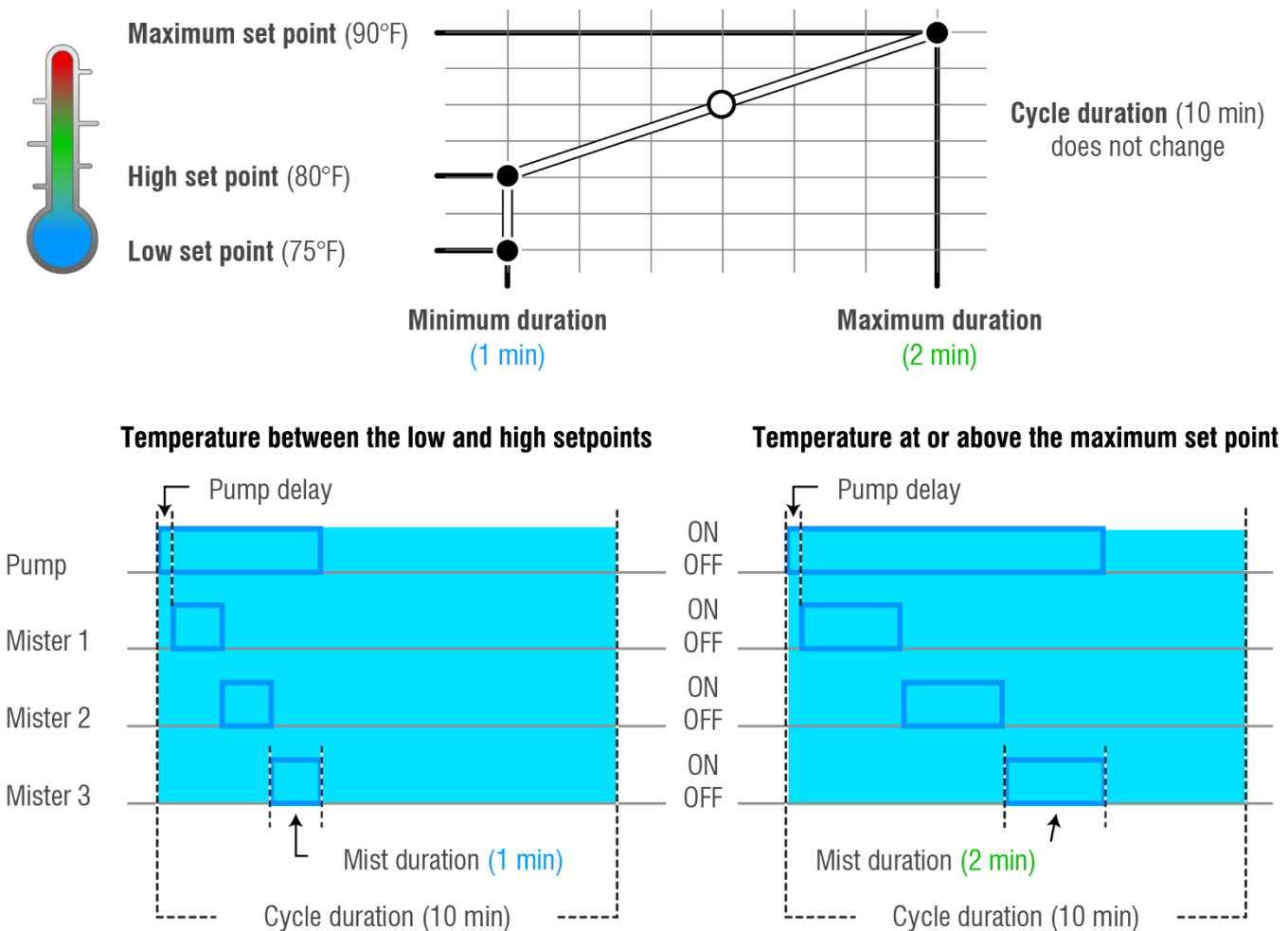

- ◆ When the temperature is below the low set point, no cooling cycle occurs.
- ◆ When the temperature is between the low and high set points, a cooling cycle occurs and the mist duration is at the minimum. In our example, this is 1:00.
- ◆ When the temperature is between the high and maximum set points, the mist duration is somewhere between the minimum and maximum durations. See point A on the graph.
- ◆ When the temperature is above the maximum set point, the mist duration is at maximum.

For a description of all settings, read **Evaporative cooling settings** on page 65.

To use misting/fogging mode

1. Press the **Menu** and then **Settings**.
2. Press **Soaking** (or **Misting**).
The Settings screen displays, with the **Settings** button selected.
3. Press the box under Mode and then select *Misting/fogging* to switch modes.
The screen will change to look like the one on the right.
4. Adjust the pump delay and active time range by pressing the arrows.
5. Press **Save** when you are finished.

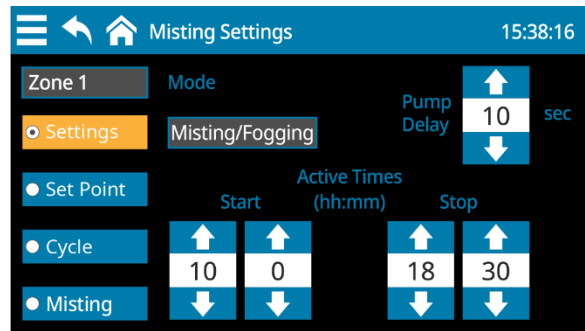

To adjust misting/fogging mode temperature or THI set points

1. Press the **Menu** and then **Settings**.
2. Press **Soaking**.
The Settings screen displays, with the **Settings** button selected.
3. Press **Set Point**.
The screen will change to look like the one on the right.
4. Adjust the set points by pressing the arrows.
5. To use humidity cutoff:
 - a) Select *Humidity Cutoff*.
 - b) Select a humidity sensor that is installed and enabled.
 - c) Adjust the cutoff value.
6. Press **Save** when you are finished.

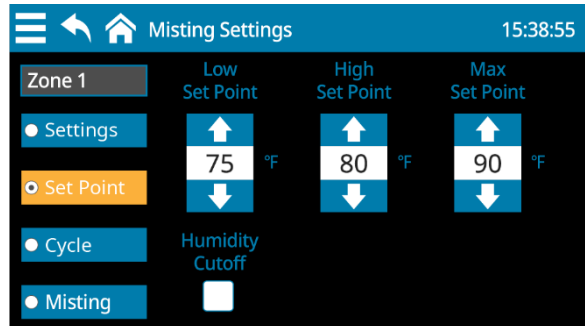

For information about humidity cutoff, read **Humidity cutoff** on page 66.

To adjust misting/fogging mode cycle duration

1. Press the **Menu** and then **Settings**.
2. Press **Misting**.
The Settings screen displays, with the **Settings** button selected.
3. Press **Cycle**.
The screen will change to look like the one on the right.
4. Adjust the cycle duration by pressing the arrows.
5. Press **Save** when you are finished.

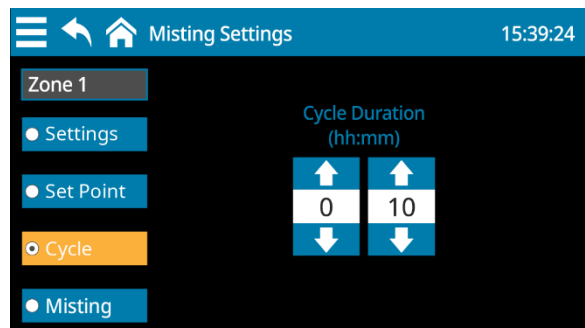

To adjust misting/fogging mode mist duration

1. Press the **Menu** and then **Settings**.
2. Press **Misting**.
The Misting Settings screen displays, with the **Settings** button selected.
3. Press **Soaking**.
The screen will change to look like the one on the right.
4. Adjust setting by pressing the arrows.
5. Press **Save** when you are finished.

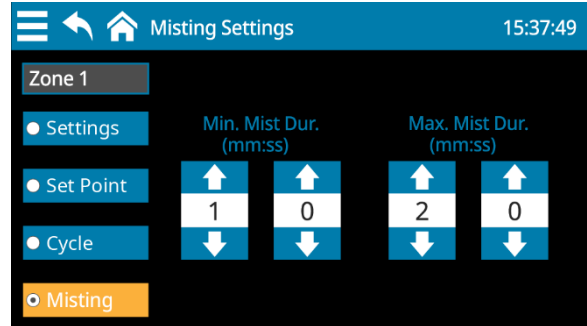

Smart mode

In smart mode, the misting and cycle durations change. As the temperature or THI rises, the misting duration gets longer and the cycle duration gets shorter. Here's an example using temperature.

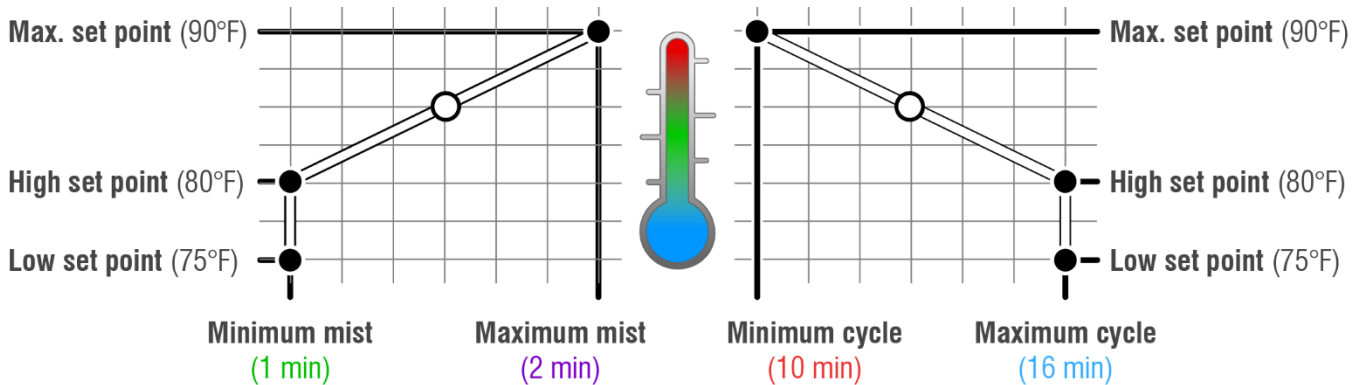

Temperature between the low and high set points

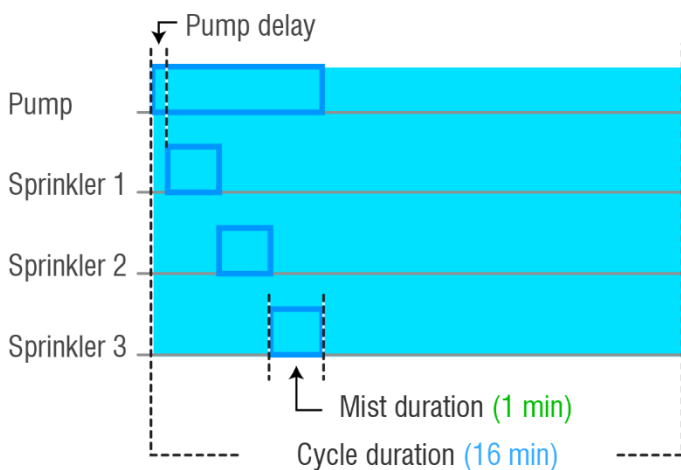

Temperature at or above the max. set point

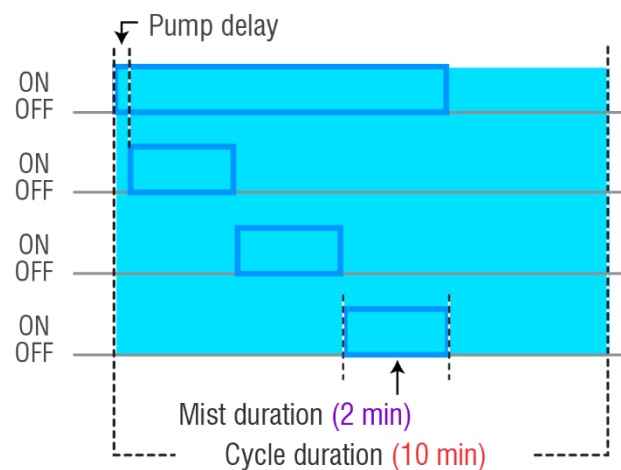

- ◆ When the temperature is below the low set point, no cooling cycle occurs.
- ◆ When the temperature is between the low and high set points, a cooling cycle occurs using the minimum misting duration and maximum cycle duration.
- ◆ When the temperature is between the high and maximum set points, the mist and cycle durations are between their minimum and maximum durations. See points A and B on the graph.
- ◆ When the temperature is above the maximum set point, the mist duration is at maximum (longest) and the cycle duration is at minimum (shortest).

For a description of all settings, read **Evaporative cooling settings** on page 65.

To use smart mode

1. Press the **Menu** and then **Settings**.
2. Press **Soaking** (or **Misting**).
The Settings screen displays, with the **Settings** button selected.
3. Press the box under Mode and then select *Smart* to switch modes.
The screen will change to look like the one on the right.
4. Adjust the pump delay and active time range by pressing the **Up** or **Down** arrows.
5. Press **Save** when you are finished.

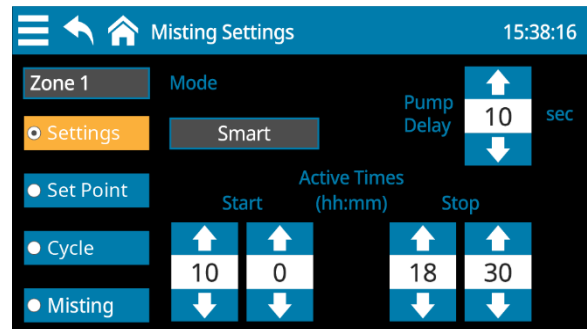

To adjust smart mode temperature or THI set points

1. Press the **Menu** and then **Settings**.
2. Press **Misting**.
The Settings screen displays, with the **Settings** button selected.
3. Press **Set Point**.
The screen will change to look like the one on the right.
4. Adjust the set points by pressing the **Up** or **Down** arrows.
5. To use humidity cutoff:
 - a. Select *Humidity Cutoff*.
 - b. Select a humidity sensor that is installed and enabled.
 - c. Adjust the cutoff value.
6. Press **Save** when you are finished.

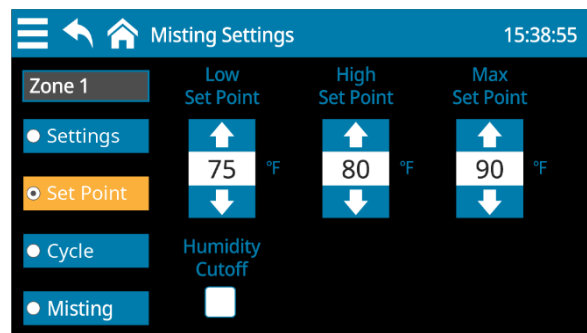

For information about humidity cutoff, read **Humidity cutoff** on page 66.

To adjust smart mode cycle durations

1. Press the **Menu** and then **Settings**.
2. Press **Misting**.
The Settings screen displays, with the **Settings** button selected.
3. Press **Cycle**.
The screen will change to look like the one on the right.
4. Adjust the minimum and maximum cycle durations by pressing the **Up** or **Down** arrows.
5. Press **Save** when you are finished.

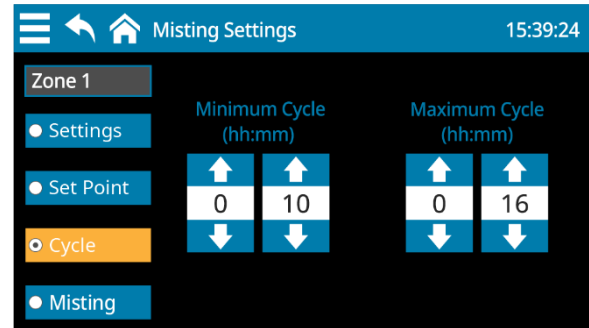

To adjust smart mode mist duration

1. Press the **Menu** and then **Settings**.
2. Press **Misting**.
The Settings screen displays, with the **Settings** button selected.
3. Press **Misting**.
The screen will change to look like the one on the right.
4. Adjust setting by pressing the **Up** or **Down** arrows.
5. Press **Save** when you are finished.

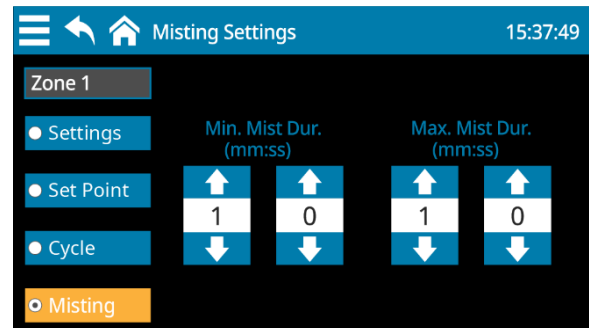

Evaporative cooling settings

General settings

Low set point

Range: 14 to 125°F (-10 to 51.7°C); 40 to 100 THI

- ◆ Soaking mode: the temperature or THI at which the cycle is at its longest (maximum) duration.
- ◆ Misting/fogging mode: the temperature or THI at which misting is at its shortest (minimum) duration.
- ◆ Smart mode: the temperature or THI at which misting is at its shortest (minimum) duration and the cycle is at its longest (maximum) duration.

There is no soaking or misting below the low set point value.

High set point

Range: 14 to 125°F (-10 to 51.7°C); 40 to 100 THI

- ◆ Soaking mode: the temperature or THI above which the cycle starts to decrease.
- ◆ Misting/fogging mode: the temperature or THI above which the misting duration starts to increase.
- ◆ Smart mode: the temperature or THI above which the cycle starts to decrease and misting duration starts to increase.

Maximum set point

Range: 14 to 125°F (-10 to 51.7°C); 40 to 100 THI

- ◆ Soaking mode: the temperature or THI above which the cycle is at its minimum duration.
- ◆ Misting/fogging mode: the temperature or THI above which misting is at its maximum duration.
- ◆ Smart mode: the temperature or THI above which the cycle is that its minimum duration and misting is at its maximum.

Humidity cutoff

During active hours, when the temperature or THI is above the low set point, if the humidity is above the humidity cutoff, pumps and solenoids will not switch on at the beginning of the cycle. This will happen until the humidity drops below the cutoff value and a new cycle begins.



- ◇ To use humidity cutoff, you must have a humidity sensor installed and enabled.
- ◇ A humidity sensor can be used for only one evaporative cooling zone.

Active start

Range: 00:00 to 23:59

The beginning of the active time each day. Sprinkler systems do not operate before this time. The time is in 24-hour format.

Active end

Range: 00:00 to 23:59

The end of the active time each day. Sprinkler systems do not operate after this time.

Pump delay

Range: 0 to 60 (sec)

The beginning of the active time of day. Sprinkler systems do not operate before this time.

Cycles

Range: 00:01 to 23:59 (hh:mm)

- ◆ **Minimum cycle** (soaking and smart modes) - The total duration of the cooling cycle when the temperature or THI is at or above the maximum temperature set point. Minimum cycle must be longer than the total of all soak durations, plus the pump delay duration.
- ◆ **Maximum cycle** (soaking and smart modes) - The total duration of the cooling cycle when the temperature or THI is between the low and high set points. Maximum cycle must be longer than the minimum cycle.
- ◆ **Cycle duration** (misting/fogging mode) - The total duration of the cycle at any temperature or THI.

Soak and mist durations

Range: 00:01 to 59:59 (mm:ss)

- ◆ **Minimum mist duration** (misting/fogging and smarts) - The duration of misting for each sprinkler the temperature or THI is at or above the maximum temperature set point.
- ◆ **Maximum mist duration** (misting/fogging and smart) - The duration of misting for each sprinkler with the temperature or THI is between the low and high set points. It must be longer than the minimum mist duration
- ◆ **Soak duration** (soaking mode) - The duration of soaking for each sprinkler. For example, if you have four sprinkler relays and the soak duration is 1 minute, each sprinkler would be on in sequence for 1 minute. Soak duration does not change as the temperature or THI increases or decreases.

Programming timed events

Timed event relays are used to control equipment that needs to be switched ON or OFF at certain times of the day. Programming timed events means selecting the relay state (ON or OFF) and the time it is to switch to that state. Each relay can have up to 32 events.

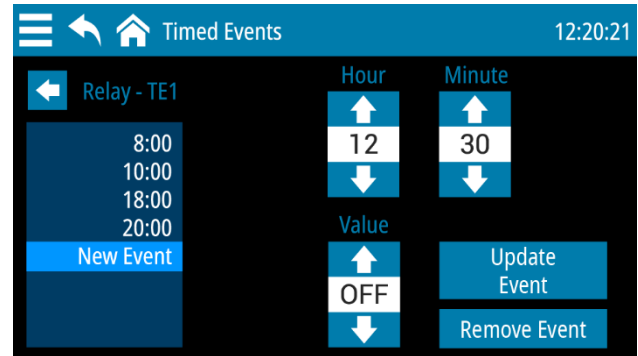
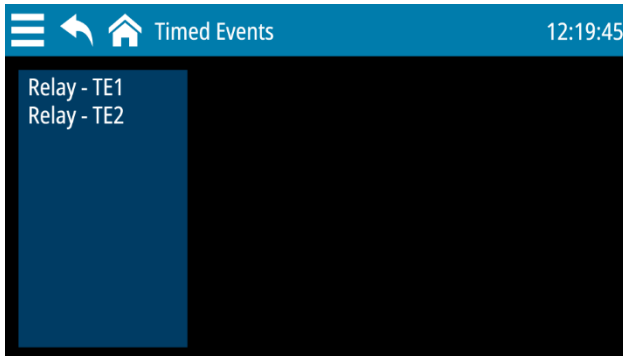

- ◇ If no relays show in the list, you have not yet configured one for timed events. For more information, read **Configuring relays** on page 33.
- ◇ Use the **Timed events worksheet** on page 94 when programming timed events.

To add or edit timed events

1. Press the **Menu** and then **Settings**.
2. Press **Timed Events**.
3. Press the relay you want to program.
4. Press an existing event to edit it, or **New Event** to create one.
5. Press the **Up** or **Down** arrows to adjust the hour, minute, and value.
6. Press **Add Event to Schedule / Update Event**.
7. Repeat steps 4 to 6 until you have finished your changes.
8. Press **Save** when you are finished.

To remove timed events

1. Press the **Menu** and then **Settings**.
2. Press **Timed Events**.
3. Press the relay you want to remove events from.
4. To remove all events, press **Remove All Events**. To remove a single event, press that event and then **Remove Event**.
5. Repeat steps 3 and 4 until you have finished your changes.
6. Press **Save** when you are finished.

Using settings groups

Settings groups allow you to have different configuration and settings for different situations. For example, you can have a settings group for each of the different seasons. When you transition from one season to another, you can switch to another group without having to reprogram the control each time.

You can create up to four settings groups. Each group has its own settings and configuration. All settings and configuration except date, time, and screen lock can be different for each group.

Only one settings group can be active. Changes you make in any of the settings and configuration screens will apply only to the active group. You can scroll through each group and view the zone control configuration by pressing the left or right arrows. To view the other settings and configuration, go to the screen for those items.

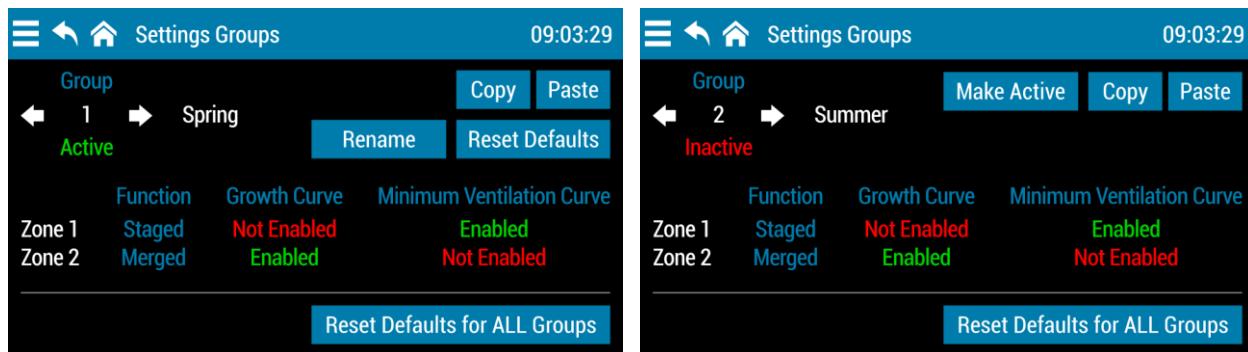

To activate a group

1. Press the **Menu** and then **Settings**.
2. Press **Configure Settings Groups**.
3. Scroll to the group you want to activate and then press **Make Active**.
The control will restart and then the selected settings group will be active.

To rename a group

1. Make sure the group you want to rename is the active group.
2. Press **Rename**.
3. Press **Reset** and then type the new name. When finished, press **Confirm** to save the change and return to the Settings Groups screen.
4. To restore the factory defaults for the group, press **Yes**. To cancel, press **No**.

To copy settings from one group to another

1. Scroll to the group you want to copy the settings from.
2. Press **Copy**. Confirm by pressing **Yes**.
3. Scroll to the group you want to copy the settings to.
4. Press **Paste**. Confirm by pressing **Yes**.

To reset the active group to factory defaults

1. Make sure the group you want to reset is the active group.
2. Press **Reset Defaults**.
A confirmation and warning message displays.
3. To restore the factory defaults for the group, press **Yes**. To cancel, press **No**.

To reset all groups to factory defaults

1. Press **Reset Defaults for ALL Groups**.
A confirmation and warning message displays.
2. To restore factory defaults for all groups, press **Yes**. To cancel, press **No**.

Chapter 5: Monitoring and maintaining your Plus Touch

- ◆ Monitoring the Status screen below
- ◆ Testing sensors and equipment on page 72
- ◆ Using screen lock security on page 74
- ◆ Servicing and maintaining your Plus Touch on page 75

Monitoring the Status screen

The Status screen displays information about each sensor and piece of equipment. Monitoring the control regularly gives you a better idea of what is going on in your facility.

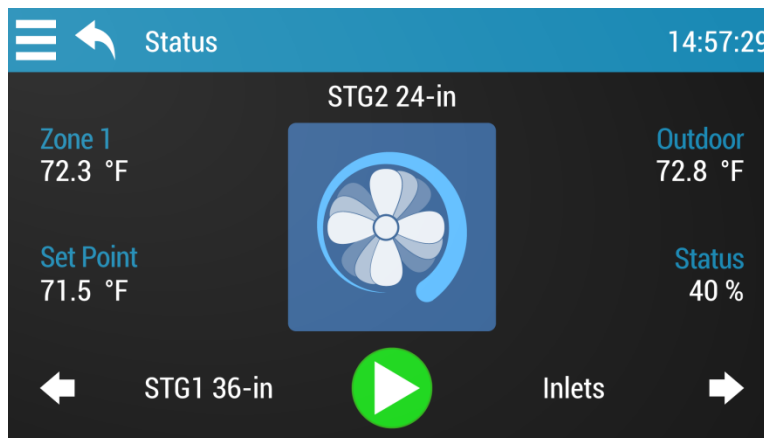







Each sensor or piece of equipment has its own status screen. Plus Touch automatically scrolls through each screen.

- ◆ To manually scroll through the screens, press the **Left** or **Right** arrows.
- ◆ To stop or start scrolling, press the **Pause/Play** button.















In the center of each status screen is a widget button. The following tables list the meaning of the button colors and icons.

Status indicators

-  **Light gray**
A sensor in normal status
-  **Blue**
Ventilation equipment that is on
-  **Green**
Equipment or sensor that is in manual override
-  **Red**
Equipment or sensor that has an alarm condition

-  **Dark gray**
Equipment that is off
-  **Orange**
Heating equipment that is on
-  **Purple**
Equipment that is affected by a modifier

Equipment icons

-  Variable cooling
-  Relay cooling
-  Relay cooling duty cycle
-  Relay follow variable cooling
-  Relay follow relay cooling
-  Actuator / inlet with feedback
-  Sprinkler, pump, or fan used for evaporative cooling
-  Variable heating
-  Relay heating
-  Relay heating duty cycles
-  Relay follow variable heating
-  Relay follow a relay heating
-  Curtain / inlet without feedback
-  Timed event

Sensor icons

-  Temperature sensor
-  Humidity sensor
-  Ammonia sensor
-  Carbon dioxide sensor

Widgets

Pressing the widget button in the center of the status screen takes you to the widget screen for the selected sensor or piece of equipment. Widget screens allow you to do some of the following, depending on the type of sensor or equipment:

- ◆ Switch between automatic and manual control
- ◆ Go to settings, modifiers, and alarms screens for the sensor or equipment.
- ◆ Calibrate and unjam actuators.
- ◆ View the current day's high and low readings for sensors.

Acknowledging alarms

An alarm occurs if an enabled alarm condition is present for longer than the minimum duration of one minute. The one-minute minimum duration prevents alarms from occurring when the temperature or THI rises or falls or just a few seconds. The exceptions to the one minute minimum are the actuator jam alarms. Actuator jam alarms activate 20 seconds after the alarm is detected.

When an alarm occurs, the alarm relay triggers (switches) and a message flashes on the screen.

To acknowledge alarms

Press **Dismiss** to silence the alarm, or **Go to Alarms** to silence and then go to alarm settings.



- ◇ Acknowledging alarms clears the alarm message; it does not deactivate the alarm relay. To deactivate the alarm relay, resolve the problem causing the alarm condition.
 - ◇ If you acknowledge the alarm, but do not resolve the problem causing the alarm condition, the alarm message displays again after the alarm silencing duration. For more information, read **Configuring alarm silencing** on page 28.
-

Testing sensors and equipment

Using manual override

Manual override allows you to override one or more sensors or pieces of equipment. Manual override is useful for testing equipment and settings, or for diagnosing problems.

- ◆ For variables, you can adjust the output.
- ◆ For relays and curtains, the state
- ◆ For actuators, the position
- ◆ For sensors, the sensor reading.

To override sensors or equipment

Option 1 - single sensor or piece of equipment

1. If you are on any screen other than the Status screen, press the **Home** button.
2. Press the **Left** or **Right** arrows to select sensor or equipment you want to override.
3. Press the widget button (the colored button in the center of the screen).
4. Press the **Up** or **Down** arrows to adjust the state, output, or reading.
Plus Touch automatically puts the item to manual override.
5. When finished, press **Auto** to return to automatic mode.

Option 2 – single or multiple sensors or equipment

1. Press the **Menu** and then **Manual Override**.
2. Press the sensor or piece of equipment you want to override.
3. Press the **Up** or **Down** arrows to adjust the state, output, or reading.
Plus Touch automatically puts the item to manual override and displays a manual override icon.
4. Repeat steps 2 and 3 for each sensor and piece of equipment you want to override.
5. When finished, press **Auto** to return the selected equipment to automatic, or **Auto All** to return all equipment.



When finished testing and overriding, set all sensors and equipment to automatic control. Any sensors or equipment you do not set to automatic will not function according to normal, programmed settings and will remain in manual override.

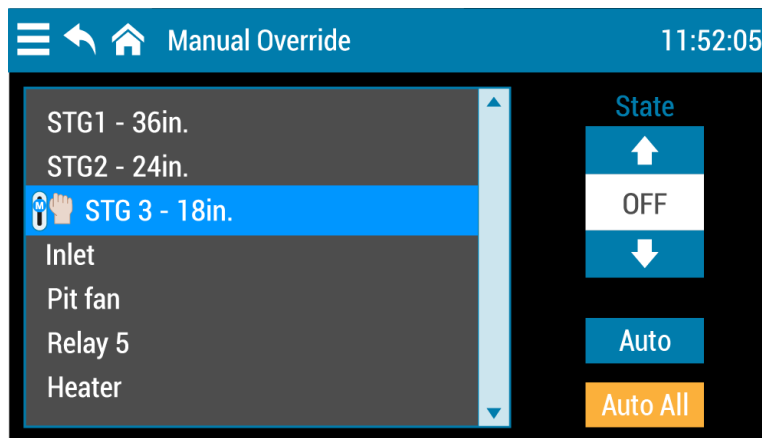

Testing a zone's sensors and equipment

Overriding a zone sensor allows you to test a zone's equipment and settings by simulating a range of temperature or THI values for the zone. As you increase or decrease the test value, the variables and relays operate according to their programmed settings and the test temperature or THI. This gives you an idea of how your system performs over a full range of values.

To test a zone

Follow the steps in **Using manual override** on page 72 and choose the zone sensor at the item you want to override.

Using screen lock security

The Plus Touch has a screen lock feature you can use to control who makes changes to the control's settings. By default, screen lock is not enabled.

While screen lock is enabled, users must enter the PIN before they can access the any of the control's functions, except the main status screen. After entering the PIN, users will not be asked again until the user locks the screen. The PIN number is a four-digit number you choose.

Locked override option

When the locked override option is enabled users will be able to manually override equipment while the screen lock is enabled, even without entering a PIN. They will not be able to access any other functions.

To lock the screen

Press the **Menu** and then **Screen Lock**.

To unlock the screen

3. Press the **Lock** and then enter the four-digit PIN.
4. Press **Unlock Screen**.

To enable and configure screen lock security

1. Press the **Menu** and then **Administration**.
2. Press **Configure Screen Lock**.
 - ◆ To enter a new PIN, press a new four-digit number. The control will accept the last four numbers you press.
 - ◆ To enable or disable screen lock or the locked override option, press the **Enabled** or **Disabled** button for that option.
3. Press **Save** when you are finished.



If the PIN has been forgotten and nobody can access the control, contact Phason technical support. For contact information, see page 97.

Servicing and maintaining your Plus Touch

Restoring the factory defaults

The Plus Touch leaves the factory with default configuration and settings. Resetting the Plus Touch erases all the configuration and settings you programmed and restores them to what they were when the control left the factory.

For a list of the factory defaults, read **Appendix B: Factory defaults** on page 84.



- ◇ **Restore the factory defaults only as a last resort. It erases ALL your configuration and settings and you will have to reconfigure the control.**
- ◇ If you restore the Plus Touch to its factory defaults, disconnect the power to all loads and then reconfigure the control before restoring power to the loads.

To restore the factory defaults

1. Press the **Menu** and then **Administration**.
2. Press **Restore Defaults**.
3. To restore defaults and remove all your configuration and settings, press **Yes**. To cancel and return to the menu, press **No**.

Saving and restoring settings

You can save or restore (load) your settings and configuration from any USB drive. You can also transfer them to any Plus Touch and set up new controls in seconds.



- ◇ We recommend regularly saving your configuration and settings to a USB drive and then keeping the drive in a safe place. This allows you to quickly set up new controls or recover your information if you install a display kit.



- ◇ The file created when saving settings to USB contains **all four settings groups** in one file.
- ◇ When you load settings from USB, the control overwrites **all four settings groups**, and then restarts. The settings group that was active before restarting will again be active.
- ◇ For more information about settings groups, read **Using settings groups** on page 68.

To save to USB

1. Loosen the four screws in the Plus Touch enclosure and then gently remove the cover. Be careful not to disconnect the ribbon cable.
2. Insert a USB drive into the USB port on the inside of the cover.
3. Press the **Menu** and then **Administration**.
4. Press **Save to USB**.
5. To save the configuration and settings, press **Yes**. To cancel and return to the menu, press **No**.
6. Remove the USB drive.
7. Replace the cover and then tighten the four screws.

To load from USB

1. Loosen the four screws in the Plus Touch enclosure and then gently remove the cover. Be careful not to disconnect the ribbon cable.
2. Insert the USB drive containing the configuration and settings into the USB port on the inside of the cover.
3. Press the **Menu** and then **Administration**.
4. Press **Load from USB**.
5. To load the saved configuration and settings, press **Yes**. To cancel and return to the menu, press **No**.
6. Remove the USB drive.
7. Replace the cover and then tighten the four screws.

Displaying the firmware version

Firmware is similar to an operating system for your computer or mobile device. Firmware contains instructions that tell Plus Touch how it operates. Just like operating systems such as Windows or Android have version numbers, the Plus Touch firmware has a version number.

If you need to contact Phason Customer Support about the Plus Touch, you might need to provide them with the firmware version of your control. For more information about technical support, read **Service and technical support** at the back of the manual.

The Plus Touch displays the firmware version as a number in the format **v#.###**.

To display the firmware version

1. Press the **Menu** and then **Administration**.
2. Press **Show Version**.

Updating the firmware

Phason constantly improves and adds new features to their products. You can upgrade the firmware in your Plus Touch as these features become available. The update takes about 20 to 30 seconds.



- ◇ You can download the latest firmware update file from <http://www.phasoncontrols.com>; just go to the **Downloads** or **Plus Touch** product page.



- ◇ The USB drive must be formatted as a **FAT32 file system**.
- ◇ You must copy the file to the **root** of the USB drive. The root means **not in a folder**.
- ◇ The following instructions are for a Windows computer.

To prepare the firmware update file

1. Insert the USB drive into your computer and then open Windows Explorer.
2. Right-click the USB drive
3. Select **Properties**.
4. Verify the file system is FAT32. If the file system is not correct, you will need to format the drive as FAT32, or use a different USB drive that is the correct format.
5. Copy the update file to the **root** of the USB drive.
6. Remove the drive.

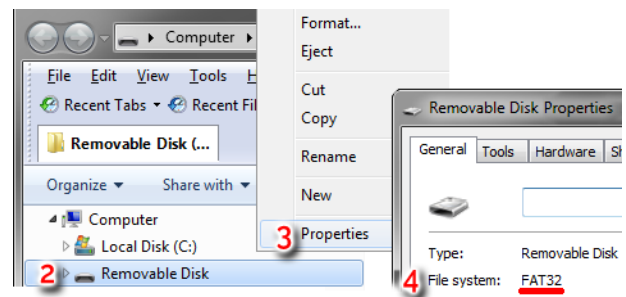

To update the firmware

1. Loosen the four screws in the Plus Touch enclosure and then gently remove the cover. Be careful not to disconnect the ribbon cable.
2. Insert the USB drive containing the update into the USB port on the inside of the cover.
3. Press the **Menu** and then **Administration**.
4. Press **Update Firmware**.
5. To update the firmware, press **Yes**. To cancel and return to the menu, press **No**.
6. After the update has finished, remove the USB drive.
7. Verify the control operates properly.
8. Replace the cover and then tighten the four screws.



- ◇ If there is a problem during the update, leave the USB drive connected and follow these steps.
- ◇ Switch off the power to the Plus Touch for 10 seconds, and then switch it on again. The control should automatically update when it restarts.

Replacement kits and optional accessories

Replacement kits and several optional, convenient accessories are available to enhance and extend the Plus Touch.

Parts and kits

Display kit

If the Plus Touch display fails, you can replace it with a kit. The display kit is model **KPT-DISPLAY**. After replacing the display, you will need to reconfigure and program control.



If you have saved your configuration and settings to a USB drive, you can restore them instead of having to reconfigure and program the control.

Control kits

If the bottom circuit board of the Plus Touch control fails, you can replace it with a kit. The control kit is model **K170048-RS**.



zConversion kits

Conversion kit model **KPEC-PLUS-TOUCH** allows you to easily convert an existing PEC Plus control to a Plus Touch.



Replacement relays

You can buy packages of replacement relays. Each relay package has five relays. The package is model number **PKG-R52**.

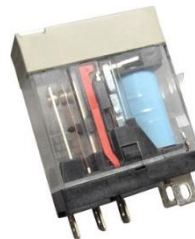

Additional sensors

Phason 3K temperature sensors and extension cable

Phason 3K temperature sensors monitor temperatures ranging from -49 to 122°F (-45 to 50°C). The sensors are available in 1, 6, 30, 75, or 150-foot cable lengths and can be extended up to 500. Extension cable is available in 500-foot lengths.



DOL 114 Temperature and Humidity Sensor

The DOL 114 is a high-precision temperature and relative humidity sensor. The special sensor element and the built-in Teflon filter enables application in facilities with constantly high humidity.

The microprocessor-controlled sensor has a two-color status and diagnostic LED. The sensor has two analog outputs with full protection against short circuits and wiring failures.



DOL 119 Carbon Dioxide Sensor

The DOL 119 sensor is designed to measure carbon dioxide (CO₂) in livestock and industrial facilities. The sensor's measuring range has been selected both to care for the animals' comfort and to monitor potential error conditions in facilities with direct combustion.

The sensor is protected by an IP67 enclosure that is waterproof and can withstand high pressure cleaning.



DOL 53 Ammonia Sensor

The DOL 53 was specifically designed to measure ammonia in livestock and industrial facilities. The long-life electrochemical will never need calibration and is not sensitive to other gases.

Accessories

Power contactors and overrides

The Manual Override Box (**model MOB-4**) increases the load handling capability of relays and provides an external disconnect. The MOB-4 includes four 240 V power contactor relays with AUTO-OFF-MANUAL switches and snubber filters. If you need to override an actuator or curtain machine, an actuator override kit is available.



Variable DC Module

The Variable DC Module (**model VDC-4**) has four 0 to 10 V outputs for controlling variable frequency drives, FanDRIVES, or other equipment requiring a DC signal input.



FanDRIVES

If you have the Variable DC Module, you can add FanDRIVES. FanDRIVES take the 0 to 10 V signal from the module and adjust fan speed. A 1×14 FLA model (FD-1-14) and a 2×7 FLA model (FD-2-7) are available.



Appendixes

This section contains reference information that is useful when installing, configuring, setting up, or troubleshooting the Plus Touch.

- ◆ **Appendix A: Troubleshooting** below
- ◆ **Appendix B: Factory defaults** on page 84
- ◆ **Appendix C: Installation worksheet** on page 85
- ◆ **Appendix D: Configuration worksheets** on page 87
- ◆ **Appendix E: Settings worksheets** on page 90
- ◆ **Appendix F: Motor curves** on page 96

Appendix A: Troubleshooting

Possible causes and solutions

The following table lists some possible causes and possible solutions for problems. See if a problem you are experiencing is described in the table and then follow the directions for correcting the problem.

Problem	Possible causes	Possible solutions
Cannot access the menu or settings	Screen lock security is enabled	◇ Enter the correct PIN. For more information, read Unlocking the screen on page 8.
Power supply components blown out Burn marks on boards and components Motors and fans slow down or stop	Power surge, brownout, or power outage	◇ Avoid the problem in future by providing proper voltage and protection for the control.
No power and/or display	A circuit breaker at service panel is off or tripped.	◇ Reset the circuit breaker.
	Incorrect wiring	◇ Correct the wiring.
	The display board connect cable is not plugged into the control board properly.	◇ Plug in the display board cable. For more information, read Bottom layout on page 12.
	The 115/230 VAC switch is in the wrong position	◇ Switch off the power, set the switch to the correct setting, and then switch on the power. For more information, read Bottom layout on page 12.
Temperature does not change	There are no working temperature sensors enabled or connected	◇ Make sure at least one working sensor is enabled. For more information, read Configuring sensor inputs on page 30.

Problem	Possible causes	Possible solutions
Unusually high or low temperature readings	A non-Phason sensor is connected to TEMP 1/2/3/4	◇ Remove the sensor and then install a Phason sensor.
	The extension cable connected to the temperature sensor is providing a poor connection	◇ Check the extension cable connection. Resolder it if necessary.
	Damaged sensor	◇ Replace the temperature sensor.
Variable fan runs at maximum	Incorrect wiring	◇ Correct the wiring. For more information, read Connecting variable heating or cooling equipment on page 18.
	The minimum idle speed is too high.	◇ Decrease the minimum idle speed setting. For more information, read Programming variable cooling stages on page 49.
	The on full at setting is the same as the temperature set point.	◇ Adjust the temperature set point to the desired temperature. For more information, read Programming variable cooling stages on page 49.
	Incorrect motor curve	◇ Configure the stage to use the other motor curve. For more information, read Configuring variable stages on page 32.
Variable fan not running	Incorrect wiring	◇ Correct the wiring. For more information, read Connecting variable heating or cooling equipment on page 18.
	The fuse is open or blown.	◇ Check why the fuse was blown and then repair any problems. Replace the fuse.
	The variable stage is configured as OFF	◇ Configure the variable stage for cooling. For more information, read Configuring variable stages on page 32.
	The idle speed setting is too low.	◇ Increase the idle speed setting. For more information, read Programming variable cooling stages on page 49. See also Programming minimum ventilation curves on page 41.
	The off at temperature setting is too high.	◇ Decrease the off at temperature setting. For more information, read Programming variable cooling stages on page 49.
	The temperature set point is above room temperature.	◇ Adjust the temperature set point to the desired temperature. For more information, read Programming variable cooling stages on page 49.
	There is no power to the fan.	◇ Switch on the power.
	Faulty fan/heater	◇ Replace the equipment.
	Circuit breaker open	◇ Reset the breaker.
Variable speed 1 or variable speed 2 fan switches on, runs at full speed, and then turns off.	The hysteresis is not high enough. The outside temperature is rising and falling quickly. This happens most often in the spring and fall.	◇ Adjust the hysteresis setting or overlap the variable speed 1 or variable speed 2 fan settings. For more information, read Configuring hysteresis on page 27.

Problem	Possible causes	Possible solutions
Variable speed fan responds to only a small portion of the 0 to 100% range	Incorrect motor curve	◇ Configure the stage to use the other motor curve. For more information, read Configuring variable stages on page 32.
Curtain opens when it should close or closes when it should open	Incorrect wiring, the close and open wires are reversed.	◇ Correct the wiring. For more information, read Connecting curtain machines on page 16
Staged heater cycles on and off	The heater set points are too close to the variable speed fan set points.	◇ Adjust the set points to be farther apart. For more information, read Programming variable cooling stages on page 49, or Programming variable heating stages on page 51.
	The heater is too large for the room	◇ Replace the heater with a smaller output unit.
	The stage is set up as a duty cycle	◇ Configure the relay as heating. For more information, read Configuring relays on page 33.
Alarm relay not operating alarm system	Incorrect wiring	◇ Correct the wiring. For more information, read Connecting an alarm system on page 20
Relay does not switch load on	Incorrect wiring	◇ Correct the wiring. For more information, read the appropriate installation section.
	The relay is configured as OFF.	◇ Configure the relay properly. For more information, read Configuring relays , starting on page 33.
	The set point is incorrect	◇ Adjust the setting. For more information, read the appropriate programming section.
	The relay is configured as cool for a heater.	◇ Change the configuration for the relay to heat. For more information, read Configuring relays , starting on page 33.
	The relay is configured as heat for a fan.	◇ Change the configuration for the relay to cool. For more information, read Configuring relays , starting on page 33.
	No power to the load	◇ Check the power and circuit breaker for the load.
	Faulty equipment	◇ Manually test the equipment and repair or replace it if necessary.
Blown relay	◇ Solve the problem that caused the relay to blow and then replace the circuit board or use a different relay.	

Determining correct actuator feedback wiring

After installing a new actuator or potentiometer, or due to age-related potentiometer wear, the actuator might not move correctly. Common symptoms include:

- ◆ The actuator oscillating back and forth
- ◆ The actuator not traveling the full stroke during calibration

The feedback potentiometer wiring must be properly connected to the control. Determining the correct wiring can be difficult on some actuators or potentiometers.

Potentiometers have three wires: positive (+), negative (-), and feedback (FB). If the feedback wire is not connected to the FB terminal on the control, the actuator will not function properly.

Because the wires are often different colors and are not always labeled the same as above, measuring the resistance between the wires is the best way to determine which wire is the feedback wire. Follow the steps below to measure the resistance and determine the correct wiring.



- ◇ Before checking the potentiometer wires, verify that the power wires are properly connected.
- ◇ Test the actuator using stage test mode.

1. Manually move the actuator away from the end of its stroke by at least a quarter of its total stroke.
2. Disconnect all three potentiometer wires from the control.
3. Number the wires 1, 2, and 3, in any order.
4. Set your ohmmeter to measure the potentiometer's maximum resistance, normally 20,000 Ω .
5. Measure and record the resistance between wires 1 and 2. _____ Ω
6. Measure and record the resistance between wires 1 and 3. _____ Ω
7. Measure and record the resistance between wires 2 and 3. _____ Ω
8. The pair of wires with the highest measured value are the positive and negative wires. Connect the wires to the positive and negative actuator terminals on the control. At this time, do not be concerned with which wire you connect to which terminal.
9. Connect the remaining wire to the feedback terminal.
10. Test the actuator using automatic mode to see if the control moves it properly. If the actuator moves in the opposite direction than it is supposed to, switch the positive and negative wires on the control.

Appendix B: Factory defaults

The Plus Touch leaves the factory with default configuration and settings. Resetting the Plus Touch erases all the configuration and settings you programmed and restores them to what they were when the control left the factory. For more information, read **Restoring the factory defaults** on page 75.

Configuration		Variable cooling	
Variable and relay stages	Not configured	Differential	86.0°F
Sensors	Not configured	Set point	80.0°F
Zone control mode	Staged, curves not enabled	Idle range	75.0°F
Temperature units	°F	Idle speed	20%
Clock	24-hour	Variable heating	
Screen lock	Off	Differential	64.0°F
Hysteresis	1.0	Set point	70.0°F
Relay stagger	5 sec	Heat cutoff	75.0°F
Alarm silencing	15 minutes	Minimum heat	20%
Master set point / growth curve		Ventilation curve	
Master set point	75.0°F	Current day	0 / off
Current day	0 / off	Step 1 start, day 4	day 1, 20%
Step 1	day 1, 85.0°F	Step 2 start, day 14	day 4, 25%
Step 2	day 4, 80.0°F	Step 3 start, day 24	day 14, 30%
Step 3	day 14, 75.0°F	Step 4 start, day 34	day 24, 35%
Step 4	day 24, 70.0°F	Step 5 start, day 44	day 34, 40%
Step 5	day 34, 65.0°F	Step 6 start, day 54	day 44, 45%
Step 6	day 44, 60.0°F	Step 7 start, day 74	day 64, 50%
Step 7	day 64, 60.0°F	Restart day	64
Restart day	64		
Inlets		Alarm settings	
Min.	SP 72°F, Pos 0%	High temperature	Not enabled / 95.0°F
Stage 1	SP 75°F, Diff 79.0, Pos 20%	Low temperature	Not enabled / 60.0°F
Stage 2	SP 79°F, Diff 81.0, Pos 40%	Sensor damage	Not enabled
Stage 3	SP 81°F, Diff 83.0, Pos 60%	Actuator jam	Not enabled
Stage 4	SP 83°F, Diff 85.0, Pos 80%		
Stage 5	SP 85°F, Diff 87.0, Pos 100%		

Evaporative cooling		Mode-specific settings			
Mode	Not enabled	<i>Soaking mode</i>		<i>Smart mode</i>	
Pump delay	10 seconds	Minimum cycle	0:15 (mm:ss)	Minimum cycle	0:15 (mm:ss)
Active times	Start 00:00 / Stop 23:59	Maximum cycle	0:15 (mm:ss)	Maximum cycle	0:15 (mm:ss)
Low set point	70.0°F	Soak duration	1:00 (mm:ss)	Minimum mist	1:00 (mm:ss)
High set point	80.0°F	<i>Misting/fogging mode</i>		Maximum mist	2:00 (mm:ss)
Max set point	90.0°F	Cycle duration	0:15 (mm:ss)		
Humidity cutoff	Not enabled	Minimum mist	1:00 (mm:ss)		
		Maximum mist	2:00 (mm:ss)		

Appendix C: Installation worksheet



Use the **Installation worksheet** when you fill in the **Configuration worksheets** (starting on page 87).

Input power	120/230 VAC, 50/60 Hz
Variable AC stages ① (VAC 1, VAC 2)	10 A at 120/230 VAC, general-purpose (resistive) 7 FLA at 120/230 VAC, PSC motor 1/2 HP at 120 VAC, 1 HP at 230 VAC, PSC motor
Fuses (2: F1 and F2)	15 A, 250 VAC ABC-type ceramic
Relays ① (6: RLY 1 to RLY 6)	10 A at 120/230 VAC, general-purpose (resistive) 1/3 HP at 120 VAC, 1/2 HP at 230 VAC 360 W tungsten at 120 VAC
Alarm relay	0.4 A at 125 VAC; 2 A at 30 VDC, resistive load 0.2 A at 125 VAC; 1 A at 30 VDC, inductive load
① You can connect more than one piece of equipment to a variable stage or relay as long as they are the same type (for example, two fans) and the total current draw does not exceed the stage's limit.	



The FLA (full load ampere) rating accounts for the increase in motor current draw when the motor operates at less than full speed. Make sure the motor/equipment connected to the variable stage does not draw more than 7 FLA.

Stage/relay	Equipment to connect
<i>Example:</i> VAR1	<i>36-inch variable speed fan, 2.5 FLA, 3/4 HP</i>
VAR 1	
VAR 2	
RLY 1	
RLY 2	
RLY 3	
RLY 4	
RLY 5	
RLY 6	
ALARM	
TEMP 1 ①	
TEMP 2 ①	
TEMP 3 ①	
TEMP 4 ①	
DOL TEMP ②	
DOL HUM ②	
DOL AUX 1 ③	
DOL AUX 2 ③	
DOL AUX 3 ③	
OUTDOOR ①	
VDC 1 ④	
VDC 2 ④	
VDC 3 ④	
VDC 4 ④	
① Phason 3K Temperature sensor only ② DOL 114 Temperature and Humidity sensor only ③ DOL119 Carbon Dioxide or DOL 53 Ammonia sensor only ④ Requires optional Variable DC Module, model VDC-4	

Appendix D: Configuration worksheets



Use the **Installation Worksheet** on page 85 when completing the configuration worksheets.

Main control function worksheet

Item	Description	Configuration		
Zone function	There are two ventilation modes, staged and VentGrid merged. For more information, read Configuring the zone control mode on page 29.	<i>Zone 1:</i>	Staged	Merged
		Growth curve	Yes	No
		Ventilation curve	Yes	No
		<i>Zone 2:</i>	Staged	Merged
		Growth curve	Yes	No
		Ventilation curve	Yes	No
Units			°C	°F
Hysteresis	Hysteresis is number of degrees above the set point that a heating stage or relay switches off, and the number of degrees below the set point that a cooling stage or relay switches off.	_____	degrees	
Relay stagger	Relay stagger prevents several relays from switching on at the same time by offsetting each relay when the control starts.	_____	seconds	

Variable stage configuration worksheet

For each variable, fill in the information as shown in the example at the top. For configuration information, read **Configuring variable stages** on page 32.

Variable	Description	Zone	Cool	Motor curve	De-icing	Heat
<i>Example:</i>						
VAC 1	Stage 1 fan	1	✓	1	✓	
VAC 2	Heat mat	1				✓
VAC 1						
VAC 2						
VDC 1 ①						
VDC 2 ①						
VDC 3 ①						
VDC 4 ①						
① Requires optional Variable DC Module, model VDC-4						

Relay configuration worksheet

For each relay, fill in the information as shown in the example table. For configuration information, read **Configuring relays** on page 33.

Relay	Description	Inlet 1 open ①	Inlet 1 close	With feedback	Inlet 2 open ②	Inlet 2 close	With feedback	Cool	Cool duty cycle	Heat	Heating duty cycle	Follow relay or variable	
1	Inlet open	✓		Yes									
2	Inlet close												
3	36-inch fan											✓	
4	Electric heat											✓	
5	Pit fan											✓	
6	Sprinkler												VAR 2

Relay	Description	Inlet 1 open ①	Inlet 1 close	With feedback	Inlet 2 open ②	Inlet 2 close	With feedback	Cool	Cool duty cycle	Heat	Heating duty cycle	Follow relay or variable
1												
2												
3												
4												
5												
6												

① Inlet 1 can be relay 1 and 2 only, with relay 1 for open and relay 2 for close.

② Inlet 2 can be relay 3 and 4 only, with relay 3 for open and relay 4 for close.

Appendix E: Settings worksheets

Settings worksheets are for you to use when programming the Plus Touch settings. Each worksheet contains a brief explanation of the information required. For more information about programming the Plus Touch, see **Chapter 4: Programming the Plus Touch** on page 37.

Growth curve worksheet

A growth curve automatically adjusts the temperature set points over time to control the temperature. You can have up to seven steps in a growth curve. Each step has a start date and temperature. Plus Touch automatically calculates the set points for the days between the steps and adjusts the set points at midnight each day. For more information, read **Programming growth curves** on page 39.

Step	Start day	Temperature
Step 1		
Step 2		
Step 3		
Step 4		
Step 5		
Step 6		
Step 7		
Temperature range: -25 to 51.7°C (-13 to 125°F)		



Temperature set points must decrease as the steps increase.

Variable stage settings worksheet

For information about programming variable stage settings, read **Programming variable cooling stages** on page 49, or **Programming variable heating stages** on page 51.

Variable	Idle speed / Minimum heat	Idle range / Heat cutoff	Set point	Differential
VAC 1				
VAC 2				
VDC 1 ①				
VDC 2 ①				
VDC 3 ①				
VDC 4 ①				

① Requires optional Variable DC Module, model VDC-4

Inlet actuators settings worksheet

The settings for the inlet actuators include the position, set point, and differential.

- ◆ When the temperature is below the minimum set point, the inlet is closed.
- ◆ When the temperature rises to the minimum set point, the inlet moves to the minimum position.
- ◆ As the temperature rises, the inlet moves through the stages until it reaches its maximum open position. This method lets you gradually open inlets instead of fully opening them when the temperature rises above a single set point.

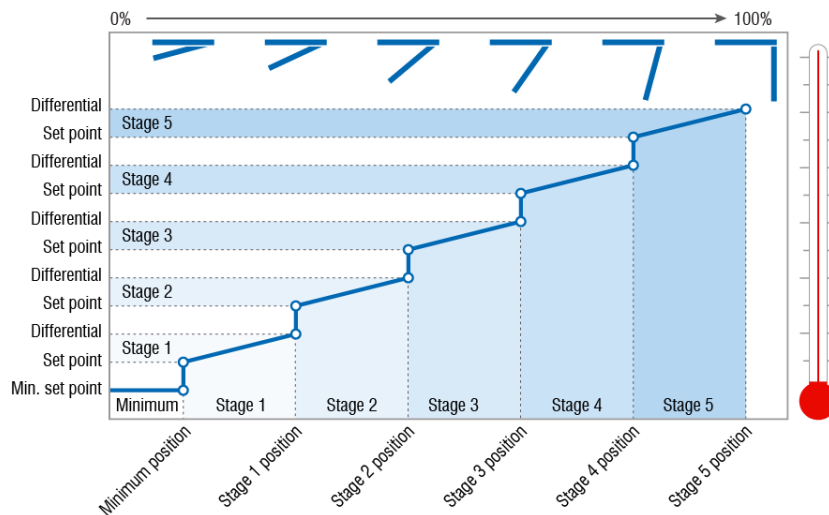

For more information, read **Programming inlet actuators** on page 53.

Setting	Actuator 1	Actuator 2	Description
			Minimum
Set point ①			The temperature below which the actuator is closed
Position ②			The percentage the actuator is open when the temperature is at or above the minimum set point
			Stage 1
Set point			The temperature at which the actuator starts opening for stage 1
Differential			The temperature at which the actuator is open to stage 1 position
Position			The percentage the actuator is open when the temperature is at the differential
			Stage 2
Set point			The temperature at which the actuator starts opening for stage 2
Differential			The temperature at which the actuator is open to stage 2 position
Position			The percentage the actuator is open when the temperature is at the differential
			Stage 3
Set point			The temperature at which the actuator starts opening for stage 3
Differential			The temperature at which the actuator is open to stage 3 position
Position			The percentage the actuator is open when the temperature is at the differential
			Stage 4
Set point			The temperature at which the actuator starts opening for stage 4
Differential			The temperature at which the actuator is open to stage 4 position
Position			The percentage the actuator is open when the temperature is at the differential
			Stage 5
Set point			The temperature at which the actuator starts opening for stage 5
Differential			The temperature at which the actuator is open to stage 5 position
Position			The percentage the actuator is open when the temperature is at the differential
① Set point temperatures in °F/ °C, range: -25 to 51.7°C (-13 to 125°F)			
② Positions in %, range: 0 to 100%			

Curtain worksheet

Curtains control the temperature by adjusting the air flow into the facility. Each curtain has six settings.

- ◆ **Set point** – the temperature at which the curtain holds its position.
- ◆ **Idle band** – the buffer around the set point within which the curtains hold their position.
- ◆ **Open run duration** – the duration the curtains open during the open cycle
- ◆ **Open idle duration** – the duration the curtains hold their position during the open cycle
- ◆ **Close run duration** – the duration the curtains close during the close cycle
- ◆ **Close idle duration** – the duration the curtains hold their position during the close cycle

For more information, read **Programming curtain control relays** on page 54.

Curtain	Set point ^①	Idle band ^②	Open run duration ^③	Open idle duration ^③	Close run duration ^③	Close idle duration ^③
			:	:	:	:
			:	:	:	:
			:	:	:	:
^① Temperature in °F/ °C, range: -25 to 51.7°C (-13 to 125°F) ^② Temperature in °F/ °C, range: 0.6 to 5.5°C (1.0 to 10.0°F) ^③ Duration in mm:ss, range: 0 to 59 minutes in 1 second increments						

Heating, cooling, and duty cycle relay worksheet

There are three types of heating and cooling relay configurations: cooling, cooling duty cycle, heating, and heating duty cycle. For more information, read:

- ◆ **Configuring relays** on page 33
- ◆ **Programming relay stages** on page 56
- ◆ **Programming duty cycles** on page 56

Relay	Type		Set point ^①	Type ^③	Duty cycle	
					ON duration ^②	OFF duration ^②
Relay 5	Heat	Ventilation		Temperature	01:30	03:00
Relay 1	Heat	Ventilation		:	:	:
Relay 2	Heat	Ventilation		:	:	:
Relay 3	Heat	Ventilation		:	:	:
Relay 4	Heat	Ventilation		:	:	:
Relay 5	Heat	Ventilation		:	:	:
Relay 6	Heat	Ventilation		:	:	:

^① Temperature in °F/ °C, range: -25 to 51.7°C (-13 to 125°F)
^② Duration in mm:ss, range: 0 to 59 minutes in 1 second increments
^③ Temperature based, time based, or persistent

Timed events worksheet

Timed event relays are used to control equipment that needs to be switched ON or OFF at certain times of the day. Programming timed events means selecting the relay state (ON or OFF) and the time it is to switch to that state. Each relay can have up to 32 events. For more information, read **Configuring relays** on page 33.

Relay	Description		Zone	
	Time ^①	Value	Time	Value
	08:00	ON	1	
	19:00	OFF	2	
			3	
			4	
			5	
			6	
			7	
			8	
			9	
			10	
			11	
			12	

^① Time can be in 12 or 24-hour format.

Appendix F: Motor curves

Motor curves provide a way to proportionally increase or decrease speed, regardless of motor manufacturer. For example, a Multifan motor might require 130 VAC to run at 50% RPM, while a Marathon motor might need 100 VAC to run at 50% RPM. Without a motor curve, the Multifan motor would run at a slower RPM than the Marathon motor at the same settings.

Selecting the correct motor curve allows you to set, for example, 50 on the control, and get much closer to 50% RPM on the motor than you would otherwise.



Use manual override or test mode to test and evaluate the operation and performance of your fan motors. For more information, read **Testing sensors and equipment** on page 72.

- ◆ If your fan motors are not running at approximately the correct RPM for the control settings, find your fan in the following table, and then select the motor curve for your fan manufacturer and model/specification.
- ◆ If your fan motor is not listed, use the default motor curve (curve 1). If the default motor curve does not operate your fan motor correctly, test the motor using manual override or test mode while selecting the different curves.

Manufacturer	Diameter (inches)	Model	Specifications	Recommended curve
Aerotech	09	AT09Z2	3350 RPM	2
	36	AT36Z1		4
Airstream	12	APP12F	1/4 HP, 1765 RPM	3
	36	APP36		4
Baldor	14		1/4 HP, 1700 RPM	4
	18		1/3 HP, 1700 RPM	4
	24		1/3 HP, 1140 RPM	4
Canarm	09	PLF9	1/5 HP	4
	12	PLF12		2
	14	PLF14		2
	16	PLF16	1/4 HP	2
	18			2
Choretime (GE)	12		1/3 HP, 1140 RPM	1
Emerson	12		1/6 HP, 3400 RPM	2
Exafan	10		1/4 HP, 1700 RPM	2
	14		1/4 HP, 1700 RPM	2
	16		1/3 HP, 1700 RPM	2
	18		1/3 HP, 1700 RPM	2
	20		0.53 HP, 1700 RPM	2
	24		0.63 HP, 1700 RPM	2

Manufacturer	Diameter (inches)	Model	Specifications	Recommended curve
Franklin	10		1/6 HP, 3450 RPM	2
Leeson	14		1/4 HP, 1625 RPM	2
	18		1/3 HP, 1625 RPM	2
	24		1/3 HP, 1140 RPM	2
	24		1/2 HP, 1625 RPM	2
	36		3/4 HP, 1625 RPM	2
Magnetek	12		1/6 HP, 3300 RPM	2
	12		1/6 HP, 1725 RPM	2
	36		1/2 HP, 840 RPM	4
Marathon	12		1/4 HP, 1625 RPM	2
	24		1/2 HP, 1625 RPM	2
Multifan	18	4E45	1600 RPM	4
	20	4E50		4

Service and technical support

Phason will be happy to answer all technical questions that will help you use the Plus Touch. Before contacting Phason, check the following:

- ◆ Read this manual for information about the feature with which you are having trouble.
- ◆ If you are having a problem using the Plus Touch, look in **Appendix A: Troubleshooting** starting on page 80 and follow the directions for correcting the problem.
- ◆ If you still have a problem with the Plus Touch, collect the following information:
 - ◆ The serial number
 - ◆ Any messages displayed by the Plus Touch
 - ◆ A description of the problem
 - ◆ A description of what you were doing before the problem occurred



- ◇ Phason controls are designed and manufactured to provide reliable performance, but they are not guaranteed to be 100 percent free of defects. Even reliable products can experience occasional failures and the user should recognize this possibility.
- ◇ If Phason products are used in a life-support ventilation system where failure could result in loss or injury, the user should provide adequate back up ventilation, supplementary natural ventilation, or an independent failure-alarm system. The user's lack of such precautions acknowledges their willingness to accept the risk of such loss or injury.

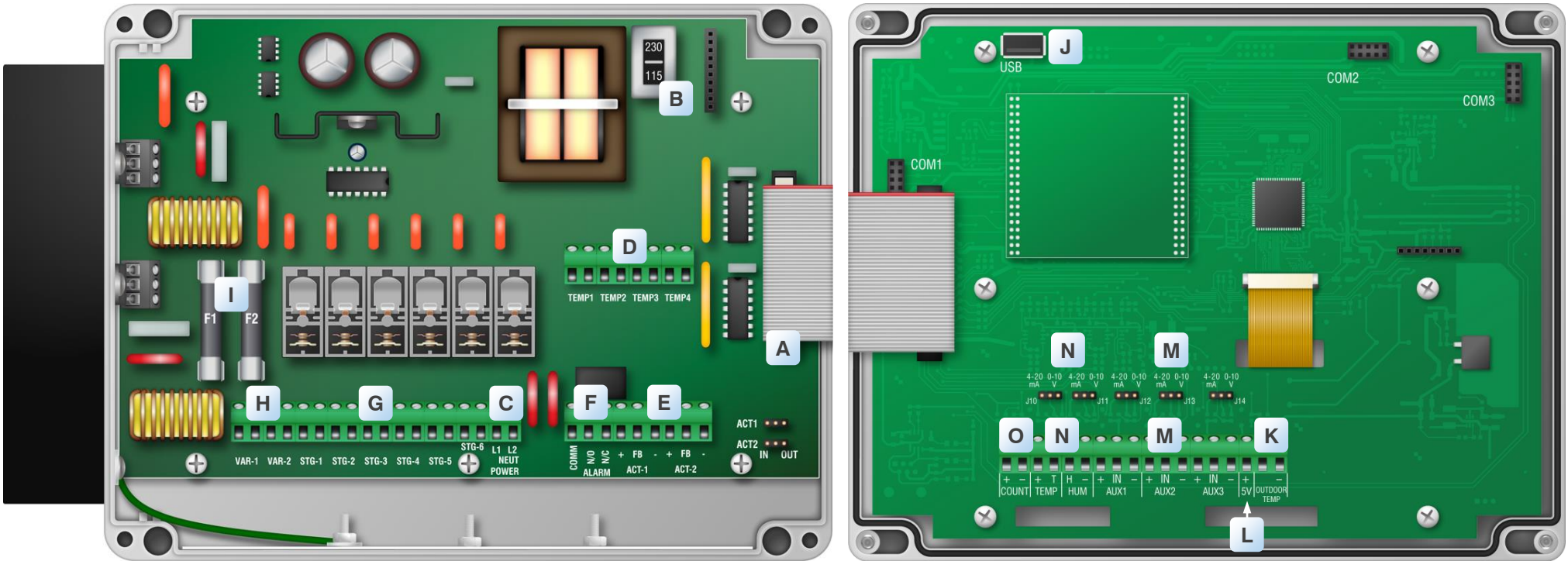

- (A) Display cable**
Disconnect the cable during installation. Reconnect it when done.
- (B) Voltage switch** ⚠️
Set the switch to the correct line voltage.
- (C) Incoming power**
Connect the incoming power from the panel.
- (D) Temperature sensor (TEMP1 to TEMP4)**
Connect the primary temperature sensor to TEMP1. Connect any additional sensors to the other terminals.
- (E) Actuator feedback (ACT-1 and ACT-2)**
Connect the feedback potentiometer from the actuator.

- (F) Alarm relay**
Connect an external alarm system or siren.
- (G) General-purpose relays (STG-1 to STG-6)**
Connect single-speed/stage heating/cooling equipment.
- (H) Variable stages (VAR-1 and VAR-2)**
Connect variable speed fans. **(I) Fuses (F1 and F2)**
The fuses are for the variable stages. F1 is for VAR-1 F2 is for VAR-2.
- (J) USB**
Connect a USB drive when saving or loading settings, or updating firmware.

- (K) OUTDOOR**
Connect a Phason 3K Temperature Sensor for measuring outdoor temperature.
- (L) +5V**
Can provide +5 VDC
- (M) DOL (M: AUX1 to AUX3)**
Connect DOL119 Carbon Dioxide or DOL 53 Ammonia Sensors. Place the jumpers on the correct pins.
- (N) DOL 114 (TEMP / HUM)**
Connect a DOL 114 Temperature and Humidity Sensor. Place the jumpers on the correct pins.
- (O) Pulse counter (COUNT)**
Not available, used for future development.

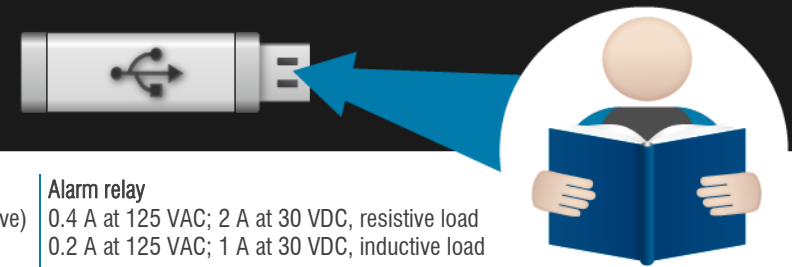

Input power
120/230 VAC, 50/60 Hz

Fuses (2: F1 and F2)
15 A, 250 VAC ABC-type ceramic

Variable stages (2: VARI-1, VARI-2)
10 A at 120/230 VAC, general-purpose (resistive)
7 FLA at 120/230 VAC, PSC motor
1/2 HP at 120 VAC, 1 HP at 230 VAC, PSC motor

Relay stages (6: STG-1 to STG-6)
10 A at 120/230 VAC, general-purpose (resistive)
1/3 HP at 120 VAC, 1/2 HP at 230 VAC
360 W tungsten at 120 VAC

Alarm relay
0.4 A at 125 VAC; 2 A at 30 VDC, resistive load
0.2 A at 125 VAC; 1 A at 30 VDC, inductive load

Mounting holes and orientation

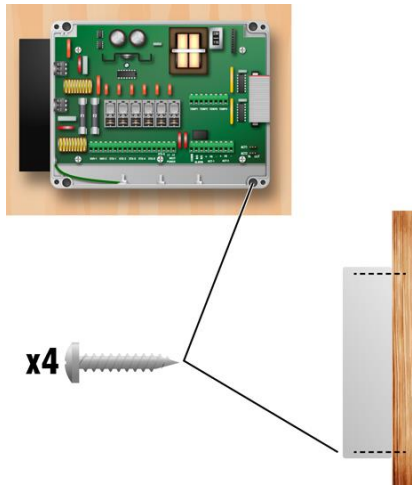

Incoming power

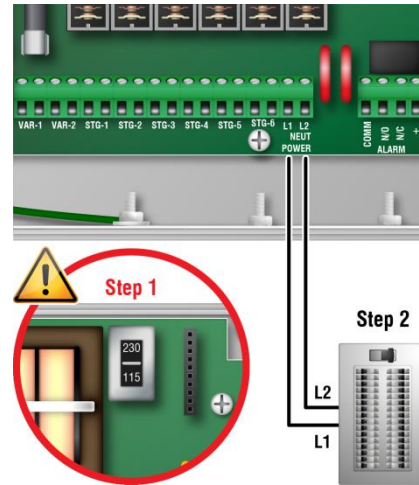

Single-speed fan or electric heater

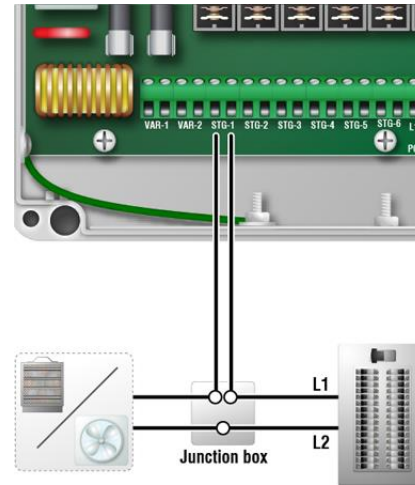

Gas-fired furnace

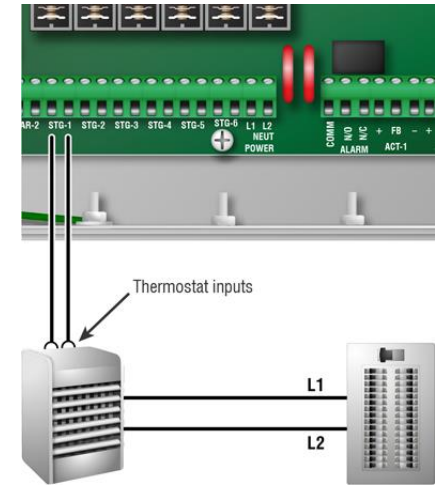

Variable speed fan

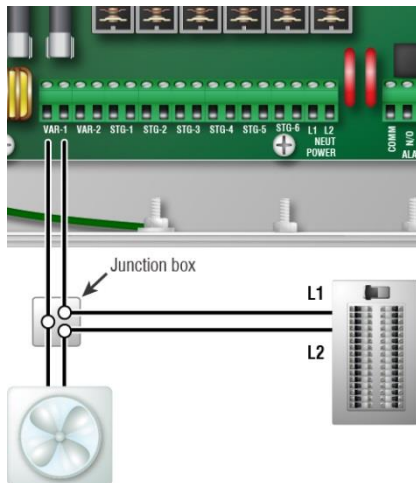

Correct three-phase wiring

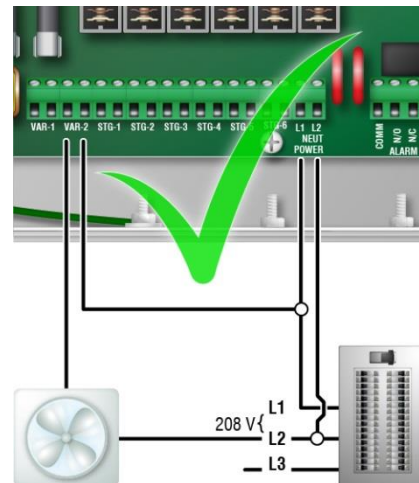

Incorrect three-phase wiring

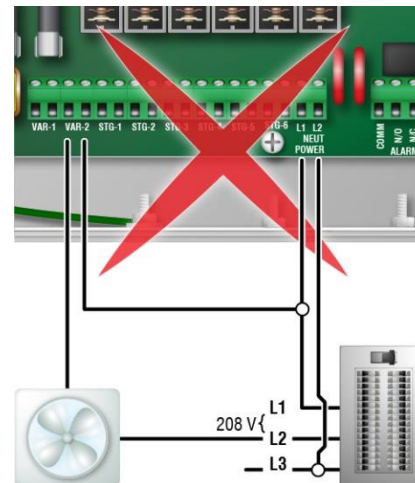

Curtain machine

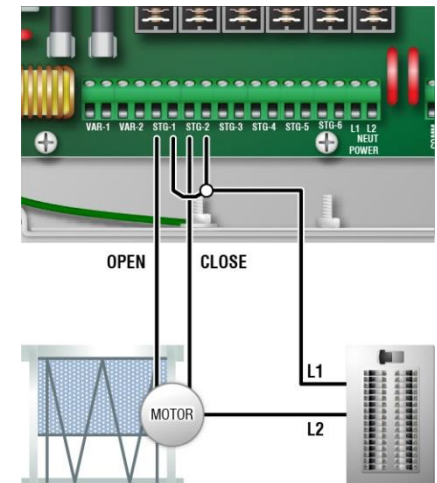



DC-powered actuator

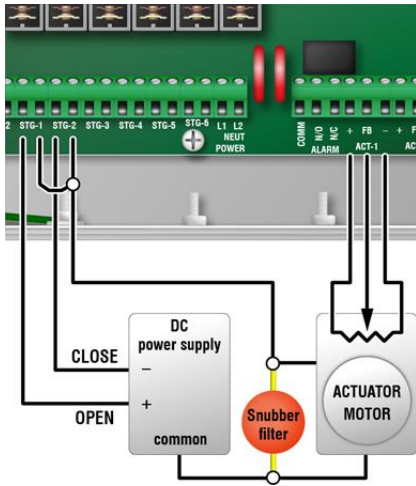

AC-powered actuator

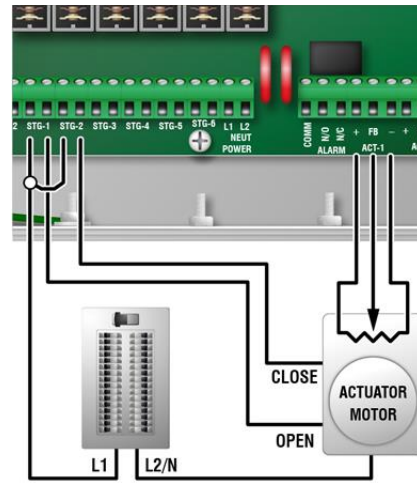

Temperature sensor

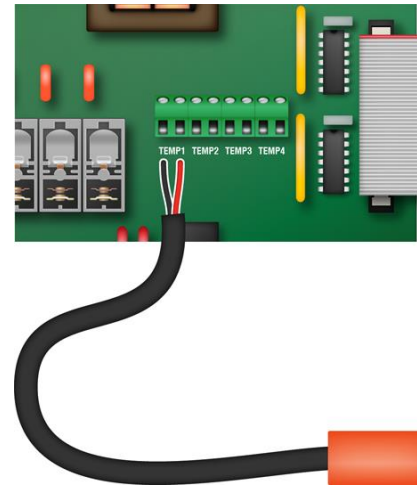

DOL 114 temperature and humidity

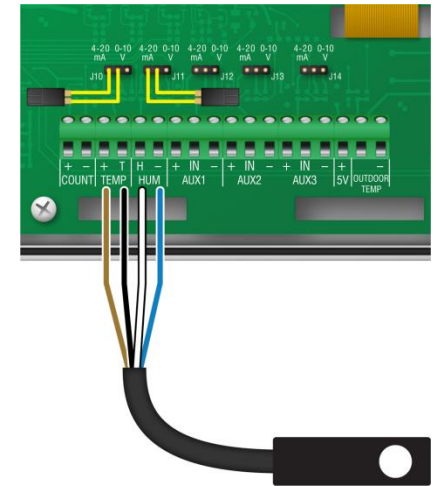

DOL 119 carbon dioxide

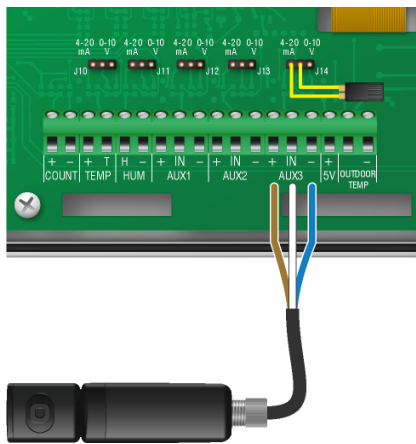

DOL 53 ammonia

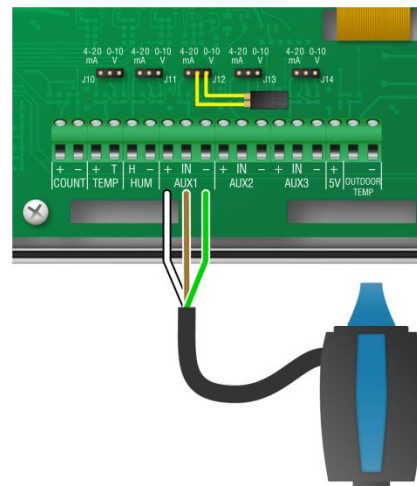

Normally open alarm system

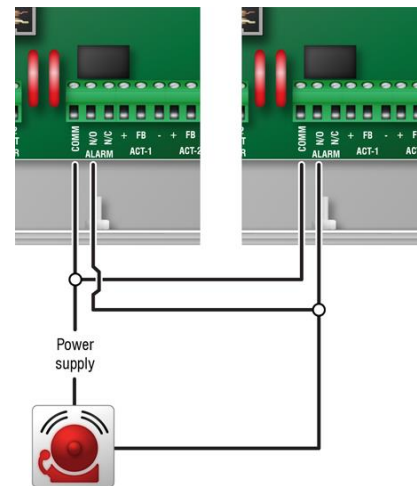

Normally closed alarm system

